

WIRELESS RF MODULE USING PIC CONTROLLER

Six Weeks Summer Training Report



PIC16F72/73 Microcontroller

AN RF MODULE IS A SMALL ELECTRONIC CIRCUIT USED TO TRANSMIT, RECEIVE, OR TRANSCIVE RADIO WAVES ON ONE OF A NUMBER OF CARRIER FREQUENCIES. RF MODULES ARE WIDELY USED IN CONSUMER APPLICATIONS SUCH AS GARAGE DOOR OPENERS, WIRELESS ALARM SYSTEMS, INDUSTRIAL REMOTE CONTROLS, SMART SENSOR APPLICATIONS, WEATHER MONITORING SYSTEM, RFID, WIRELESS MOUSE TECHNOLOGY AND WIRELESS HOME AUTOMATION SYSTEMS. THEY ARE OFTEN USED INSTEAD OF INFRARED REMOTE CONTROLS AS THEY HAVE THE ADVANTAGE OF NOT REQUIRING LINE-OF-SIGHT OPERATION.

PROJECT BY ABHI SHARMA

ABSTRACT

THE RADIO FREQUENCY MODULE IS BASICALLY A PIC MICROCONTROLLER BASED WIRELESS COMMUNICATION SYSTEM. WIRELESS RF MODULE TECHNOLOGY ENABLES A VAST EDGE TO ANY ELECTRONICS PROJECT & PROVIDE MANY CONSISTENT ADVANTAGES, WHICH LEADS IT TO TODAY'S UP-TO-DATE TECHNOLOGY. AN RF MODULE IS A SMALL ELECTRONIC CIRCUIT USED TO TRANSMIT, RECEIVE, OR TRANSCIVE A RADIO WAVES ON ONE OF A NUMBER OF CARRIER FREQUENCIES. RF MODULES ARE WIDELY USED IN CONSUMER APPLICATIONS SUCH AS GARAGE DOOR OPENERS, WIRELESS ALARM SYSTEMS, INDUSTRIAL REMOTE CONTROLS, SMART SENSOR APPLICATIONS AND WIRELESS HOME AUTOMATION SYSTEMS. THEY ARE OFTEN USED INSTEAD OF INFRARED REMOTE CONTROLS AS THEY HAVE THE ADVANTAGE OF NOT REQUIRING LINE-OF-SIGHT OPERATION.

RADIO FREQUENCY INVOLVES TWO SUB UNITS NAMED, TRANSMITTER & RECEIVER. AS THEIR NAME IMPLIES TRANSMITTER IS USED TO TRANSMIT OR TO SEND THE DATA FROM INPUT & IT CONVERT INTO SERIAL PORT DATA BY USING HT12E ENCODER. THIS ENCODED DATA GET RECEIVED BY RECEIVER PLACING FAR AWAY FROM IT. THE FIRST JOB THAT A RECEIVER DO AFTER RECEIVING IT, IS TO CONVERT OR DECODE THE DATA INTO PARALLEL PORTS BY USING HT12D DECODER. AFTER CONVERTING THE DATA INTO PARALLEL FORM WE SIMPLY CONNECT THE RECEIVER SIDE CIRCUIT WITH RELAY SO THAT WE CAN OPERATE AC DEVICES (e.g. BULB, TUBE, FAN ETC.) WITH RF MODULE.

AND, ABOUT THE MATTER TECHNOLOGY THAT I HAVE USED IS PIC16F73. THE TECHNOLOGY OF ANY PROJECT IS CONSIDERED AS THE HEART AS WELL AS THE MIND TO IT. THE BIGGEST CONCERN TO ANY STUDENT OR TRAINEE REMAINS THAT THE TECHNOLOGY HE'S GOING LEARN MUST BE UP-TO-DATE AND MUST TO BE IN INDUSTRY'S INTEREST. SO, THAT'S WHY I'VE CHOSEN PIC SERIES OF MICROCONTROLLERS. THEY ARE COST EFFECTIVE, PROVIDE WIDE AVAILABILITY, LARGE USER BASE, EXTENSIVE COLLECTION OF APPLICATION NOTES, AVAILABILITY OF LOW COST OR FREE DEVELOPMENT TOOLS, AND SERIAL PROGRAMMING (AND RE-PROGRAMMING WITH FLASH MEMORY) CAPABILITY.

THE VERY FIRST THING THAT CONCERN TO ANY ELECTRONICS ENGINEERING STUDENT BEFORE CHOOSING THE PROJECT IS IT'S APPLICATIONS. THAT MEANS HOW MUCH INNOVATIVE THE PROJECT IS ? AND HOW WE CAN MAKE IT MORE INNOVATIVE & ALSO MAKE IT UP-TO-DATE SO THAT IT CAN EXTEND TO THE BIGGER APPLICATIONS OF THIS AGE OF SMART & VAST LIFE.? AND, ALSO IT'S APPLICATIONS MUST BE COST EFFECTIVE SO THAT EVERYONE CAN USE IT WITHOUT ANY ECONOMICAL HESITATION. THERE ARE NUMEROUS APPLICATIONS OF WIRELESS RF MODULE. AS, TODAY'S ONE OF THE VAST & LEADING TECHNOLOGY NAMED RFID IS BASED ON THIS PRINCIPLE OF RF MODULE. THE WIRELESS MOUSE ALSO WORK ON THE SAME PRINCIPLE. AND, BEYOND THEM INDUSTRIAL AUTOMATION, CUSTOM WIRELESS REMOTE CONTROLS LIKE WIRELESS X-RAY SYSTEMS & LONG-RANGE WIRELESS SWITCH SYSTEM (HAND-HELD), MACHINE TO MACHINE (M2M) RF WIRELESS NETWORKING, ROBOT CONTROL , WEATHER MONITORING SYSTEM & IDENTIFYING OBJECTS USING RF TRANSMITTERS AND RECEIVERS AND RETRIEVING DATA USING GSM ETC. COULD BE CONSIDERED AS IT'S FUTURE PROSPECTS TO WORK ON. THIS IS INDEED A GREAT PROJECT TO WORK ON.!



ACKNOWLEDGEMENT

IT WOULD BE INAPPROPRIATE TO CALL THIS REPORT COMPLETE AND SUCCESSFUL, IF I DON'T THANK THE PEOPLE WHO GUIDED AS IN THE PREPARATION OF THIS PROJECT. THE SUBMISSION OF THIS PROJECT REPORT GIVES ME AN OPPORTUNITY TO CONVEY MY GRATITUDE TO ALL THOSE WHO HAVE HELPED ME TO REACH STAGE FROM WHERE I HAVE IMMENSE CONFIDENCE TO LAUNCH MY CAREER IN THE COMPETITIVE WORLD OF ELECTRONICS ENGINEERING.

FIRST AND FOREMOST, I WOULD LIKE TO ACKNOWLEDGE MY HEARTY THANKS TO THE RESPECTED **MR. |-----|**, HOD (ECE) FOR BEING A SOURCE OF PERPETUAL INSPIRATION AND FOR PROVIDING ME SUCH A NICE ENVIRONMENT FOR TRAINING WITH TIMELY HELP.

I WOULD ALSO LIKE TO EXPRESS MY MOST SINCERE GRATITUDE AND INDEBTEDNESS TO MY GUIDE **MR. |-----|** FOR THEIR VALUABLE HELP DURING THE DEVELOPMENT OF THIS PROJECT. WITHOUT HIS PRICELESS SUGGESTION AND TIMELY HELP I WOULD NOT BE ABLE TO COMPLETE THIS PROJECT. HE HAS BEEN A SOURCE OF PERPETUAL INSPIRATION TO ME, TOWARDS A BRIGHT CAREER. NOT TO FORGET THE PAIN STAKING EFFORTS OF MY COLLEGE TRAINING AND PLACEMENT CELL. LAST BUT NOT THE LEAST I WOULD EXPRESS MY UTMOST REGARDS FOR THE ELECTRONICS AND COMMUNICATION DEPARTMENT OF MY INSTITUTE.

*ABHISHEK SHARMA
B-TECH.
ECE - 4TH SEM.*

CONTACT ME



LIST OF TABLES & FIGURES USED

<i>Tables</i>		<i>Page No.</i>
<i>Fig: 6.6.2</i>	<i>Feature Table Of PIC16F73</i>	<i>27</i>
<i>Fig: 9.3</i>	<i>Frequencies Table Of RF</i>	<i>39</i>
Figures		
<i>Fig: 4.1.1</i>	<i>Types Of OrCAD</i>	<i>8</i>
<i>Fig: 4.3.1</i>	<i>A Still Of MikroC</i>	<i>12</i>
<i>Fig: 5.3.4</i>	<i>The Procedure Of PCB Designing Using OrCAD</i>	<i>16</i>
<i>Fig: 5.4.2</i>	<i>Designing a Circuit In Capture CIS</i>	<i>18</i>
<i>Fig: 5.5.3</i>	<i>Designing a PCB Footprint in Layout Plus</i>	<i>20</i>
<i>Fig: 6.0</i>	<i>Various PIC Microcontrollers Offered By Microchip</i>	<i>21</i>
<i>Fig: 6.6</i>	<i>Pin Diagram Of PIC16F73</i>	<i>24</i>
<i>Fig: 6.8</i>	<i>Flowchart Of PIC & It's Core Architecture</i>	<i>28</i>
<i>Fig: 6.9.1</i>	<i>Voltage-Frequency Graph Of PIC</i>	<i>29</i>
<i>Fig: 9.3.1</i>	<i>RF Frequency Spectrum</i>	<i>40</i>
<i>Fig: 9.5</i>	<i>Block Diagram Of RF Operation</i>	<i>40</i>
<i>Fig: 9.5.1</i>	<i>Transmitter/Receiver Explained</i>	<i>41</i>
<i>Fig: 9.8</i>	<i>RF Module</i>	<i>45</i>
<i>Fig: 9.9.1</i>	<i>Operation Of Serial Encoder</i>	<i>46</i>
<i>Fig: 9.9.2</i>	<i>Operation Of Serial Decoder</i>	<i>47</i>
<i>Fig: 9.10</i>	<i>Flowchart Of RF Module</i>	<i>48</i>
<i>Fig: 11.1.1</i>	<i>RFID</i>	<i>51</i>
<i>Fig: 11.2.4</i>	<i>Wireless RF Based Mouse</i>	<i>53</i>
<i>Fig: 11.5</i>	<i>M2M PIC Tail Daughter Board</i>	<i>55</i>
<i>Fig: 11.6</i>	<i>Flowchart Of RF Based Control Robot</i>	<i>56</i>

TABLE OF CONTENT

<i>Chapter No.</i>	<i>Title</i>	<i>Page No.</i>
	<i>Title Page</i> _____	<i>i</i>
	<i>Abstract</i> _____	<i>ii</i>
	<i>Acknowledgement</i> _____	<i>iii</i>
	<i>List Of Tables & Figures</i> _____	<i>iv</i>
1.	INTRODUCTION _____	1
1.1	<i>What is Wireless.?</i> _____	1
1.2	<i>Examples Of Wireless Devices</i> _____	2
1.3	<i>Radio Frequency</i> _____	2
1.4	<i>What is RF Module ?</i> _____	2
1.5	<i>RF Module's Performance</i> _____	2
1.6	<i>Scope of Wireless RF Module</i> _____	3
2.	Features Of RF Module _____	4
3.	Hardware & Software Requirements _____	5
3.1	<i>Input Requirement</i> _____	5
3.2	<i>Output Requirement</i> _____	5
3.3	<i>Software Requirement</i> _____	6
3.4	<i>Hardware Requirement</i> _____	6
4.	Tools To be Used _____	7
4.1	<i>OrCAD</i> _____	8
4.1.1	<i>PCB Designing</i> _____	8
4.1.2	<i>Layout Plus</i> _____	9
4.1.3	<i>Capture CIS</i> _____	9
4.2	<i>PIC Burner</i> _____	10

	4.3	<i>MikroC</i>	11
	4.4	<i>USB PIC Bootloader</i>	13
5.		PCB Designing	14
	5.1	<i>Types Of PCB</i>	14
	5.2	<i>Function Of PCB</i>	14
	5.3	<i>Techniques Used</i>	15
	5.4	<i>OrCAD Design Environment</i>	17
	5.5	<i>Placement Of Layout Plus</i>	19
6.		Technology To be Used	21
	6.1	<i>Introduction</i>	22
	6.2	<i>Special Microcontroller Features</i>	22
	6.3	<i>Peripheral Features</i>	23
	6.4	<i>CMOS Technology</i>	23
	6.5	<i>Data Space (RAM)</i>	23
	6.6	<i>PIN Diagram</i>	24
	6.6.1	<i>PIN Description</i>	25
	6.6.2	<i>Feature Table</i>	27
	6.7	<i>Memory Organization</i>	27
	6.8	<i>Core Architecture</i>	28
	6.9	<i>USART</i>	29
7.		Project Planning	30
	7.1	<i>Project Planning & Scheduling</i>	30
8.		Requirement Analysis	31
	8.1	<i>Listing The Components</i>	
	8.1.1	<i>Components</i>	32
	8.1.2	<i>PCB</i>	32
	8.1.3	<i>Capacitor</i>	32
	8.1.4	<i>L.E.D</i>	33
	8.1.5	<i>L.C.D</i>	33
	8.1.6	<i>Relay</i>	34
	8.1.7	<i>Resistor</i>	34
	8.1.8	<i>BX433A</i>	35
	8.1.9	<i>ULN280 1A</i>	35
	8.1.10	<i>Battery</i>	35
	8.1.11	<i>HT12E/ Encoder</i>	36
	8.1.12	<i>HT12D/ Decoder</i>	36
	8.1.13	<i>PIC16F73</i>	37

9.	Working Of RF Module	38
9.1	<i>Special Properties Of RF Current</i>	38
9.2	<i>Frequency Chart</i>	39
9.3	<i>RF Module Interfacing With PIC</i>	40
9.4	<i>Block Diagram & Explanation</i>	40
9.5	<i>Source Code For PIC</i>	43
9.6	<i>Serial Encoder/Decoder</i>	44
9.7	<i>Operational Working Of RF</i>	45
9.8	<i>Ckt Implementation</i>	46
9.8.1	<i>Transmitter Section</i>	46
9.8.2	<i>Receiver Section</i>	47
9.9	<i>Working Flowchart</i>	48
10.	What is Hex File Format.?	49
10.1	<i>Structure Of Hex File Format</i>	49
11.	Applications Of RF Module	50
11.1	<i>RFID</i>	50
11.1.1	<i>Operation Of RFID</i>	50
11.1.2	<i>Applications Of RFID</i>	51
11.2	<i>Wireless Mouse</i>	52
11.2.1	<i>RF Transmitter</i>	52
11.2.2	<i>RF Receiver</i>	52
11.2.3	<i>RF Frequency</i>	52
11.2.4	<i>Advantages</i>	53
11.3	<i>Industrial Automation</i>	53
11.4	<i>Custom Wireless Remote Controls</i>	54
11.4.1	<i>Wireless X-Ray System</i>	54
11.4.2	<i>Long Range Transmitter</i>	54
11.5	<i>Machine to Machine Wireless RF Networking</i>	55
11.6	<i>Robot Using RF Remote Control</i>	56
12.	Actual PCB Photographs	57
13.	Future Of Project	59
13.1	<i>Identifying Objects Using RF Technology</i>	59
13.2	<i>Radio Transmitter Design</i>	59
13.3	<i>Two Channels RF Control</i>	60
13.4	<i>Weather Monitoring System</i>	60
14.	Appendix	61
15.	Bibliography	62

1. INTRODUCTION

1.1 What is wireless ?

Wireless is a term used to describe telecommunications in which electromagnetic waves (rather than some form of wire) carry the signal over part or all of the communication path. Some monitoring devices, such as intrusion alarms, employ acoustic waves at frequencies above the range of human hearing; these are also sometimes classified as wireless.

Wireless technology is rapidly evolving, and is playing an increasing role in the lives of people throughout the world. In addition, ever-larger numbers of people are relying on the technology directly or indirectly. (It has been suggested that wireless is overused in some situations, creating a social nuisance.)

1.2 EXAMPLES OF WIRELESS DEVICES

- **Cellular phones and pagers** -- provide connectivity for portable and mobile applications, both personal and business
- **Global Positioning System (GPS)** -- allows drivers of cars and trucks, captains of boats and ships, and pilots of aircraft to ascertain their location anywhere on earth
- **Cordless computer peripherals** -- the cordless mouse is a common example; keyboards and printers can also be linked to a computer via wireless
- **Cordless telephone sets** -- these are limited-range devices, not to be confused with cell phones
- **Home-entertainment-system control boxes** -- the VCR control and the TV channel control are the most common examples; some hi-fi sound systems and FM broadcast Receivers also use this technology
- **Remote garage-door openers** -- one of the oldest wireless Devices in common use by consumers; usually operates at Radio frequencies
- **Two-way radios** -- this includes Amateur and Citizens Radio Service, as well as business, marine, and military Communications
- **Baby monitors** -- these devices are simplified radio transmitter/receiver units with limited range
- **Satellite television** -- allows viewers in almost any location to select from hundreds of channels.



1.3 RADIO FREQUENCY

Radio Frequency (RF) is a rate of oscillation in the range of about 3 kHz to 300 GHz, which corresponds to the frequency of radio waves, and the alternating currents which carry radio signals. It is the use of radio signals to communicate real-time data from the warehouse floor to the WMS database and back to the floor.

This expedites processing in the warehouse. Scanners collect the data and transmit it via radio frequency to antennas located throughout the warehouse.

From the antennas, the signal proceeds to an access point that communicates with the warehouse management system. This process reduces paper, data entry time delays, cycle count processing, out of stock quantities, typing errors, and misshipments.

1.4 WHAT IS RF MODULE?

An RF Module is a (usually) small electronic circuit used to transmit, receive, or transceive radio waves on one of a number of carrier frequencies. RF Modules are widely used in consumer application such as garage door openers, wireless alarm systems, industrial remote controls, smart sensor applications, and wireless home automation systems. They are often used instead of infrared remote controls as they have the advantage of not requiring line-of-sight operation.

1.5 MAIN FACTOR AFFECTING RF MODULE'S PERFORMANCE

As with any other radio-frequency device, the performance of an RF Module will depend on a number of factors. For example, by increasing the transmitter power, a larger communication distance will be achieved. However, this will also result in a higher electrical power drain on the transmitter device, which will cause shorter operating life for battery powered devices.

Also, using a higher transmit power will make the system more prone to interference with other RF devices, and may in fact possibly cause the device to become illegal depending on the jurisdiction.

1.6 TYPICAL APPLICATIONS/SCOPE OF WIRELESS RF MODULE

- Vehicle Monitoring
- Remote Control
- Telemetry
- Small-Range wireless network
- Wireless meter reading
- Access control systems
- Wireless home security systems
- Area paging
- Industrial data acquisition system
- Radio tags reading
- RF contact less smart cards
- Wireless data terminals
- Wireless fire protection systems
- Biological signal acquisition
- Hydrological and meteorological monitoring
- Robot remote control
- Wireless data transmissions
- Digital video/audio transmission
- Digital home automation, such as remote light
- Industrial remote control and remote sensing
- Remote control for household appliances and Electronics projects
- Mobile web server for elderly people monitoring

2. FEATURES OF RF MODULE

THERE ARE SEVERAL FEATURES OF WIRELESS RF MODULE:

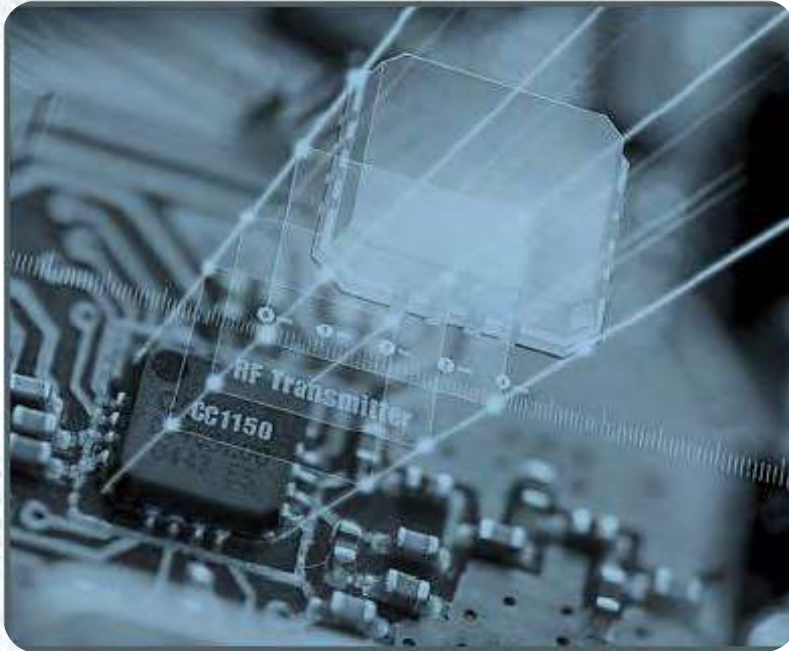

The RF Transmitter and Receiver modules provide a simple to use RF data link at up to 300GHz from any standard CMOS/TTL source. The modules are very simple to operate and offers low current consumption. Data can be supplied directly from a microprocessor or encoding device, thus keeping the component count down and ensuring a low hardware cost. These modules exhibit extremely stable electronic characteristics due to the use of Etched The PCB In OrCAD Technology, which uses no adjustable components and ensures very reliable operation.

- Interference Immunity
- Low Power Required
- Receiver Sensitivity
- RF Basics
- Wireless Data Communication
- Wireless Transceiver Modules
- Reliable
- Power Efficient
- Long Range Communication
- 3KHz - 300GHz of Range
- Cost Effective
- Small size (QLP 4x4 mm package)
- True single chip UHF RF transmitter
- Frequency bands: 300-348 MHz, 400-464MHz and 800-928 MHz
- Programmable data rate up to 500kbaud
- Low current consumption
- Programmable output power up to +10dBm for all supported frequencies
- Programmable baseband modulator
- Ideal for multi-channel operation
- Very few external components:
- Completely on-chip frequency Synthesizer,
- no external filters needed
- Configurable packet handling hardware
- Suitable for frequency hopping systems due to a fast settling frequency synthesizer
- Optional Forward Error Correction with interleaving
- Many powerful digital features allow a high-performance RF system to be made using an inexpensive microcontroller
- Efficient SPI interface: All registers can be programmed with one "burst" transfer
- Integrated analog temperature sensor
- Support for asynchronous transparent transmit mode for backwards compatibility with existing radio communication protocols

3. HARDWARE & SOFTWARE REQUIREMENTS

3.1 INPUT REQUIREMENTS

The Wireless RF Module has following Input Requirements:

- The CPU Must Has 8-Pin Port So that The Serial Port Can Be Inserted for Burning Purposes.
- If We have a Laptop Then Universal USB To Serial Port Converter Could be Used For Burning.
- PIC IC is Most Important For Input The Source Code in It.
- Mikro C is Also used as Input Required Software.
- Any kind of sensors are also usable as input requirement.

3.2 OUTPUT REQUIREMENTS

For Getting the output we can use any hardware devices as follows. It all depends upon our programming requirements. As:

- LCD Can be used To Receive The Output of the PIC.
- LED or 7-Segments offers the Same properties as of LCD.
- DC Motor or Stepper Motors or Relays are also used as output Requirement devices.
- We can also use PS/2 keyboards & ADC Ports etc.

3.3 SOFTWARE REQUIREMENTS

- Windows , LINUX as an operating system.
- OrCAD as work space for PCB designing.
- TINA PRO for Simulation Purposes.
- Mikro C as a Compiler for Embedded C.
- PIC Burner.
- Boot Loader.

3.4 HARDWARE REQUIREMENTS

- Pentium 4 Computer(Atleast).
- 256 MB RAM.
- Software Interfacing with PIC 16F73 Kit.
- Universal USB to Serial Port Convertor Using Laptop.
- 8-Pin serial port for burning the IC using CPU.
- Keyboard.
- Hard disk (20 GB).
- Mouse.

4. Tools Used For Development

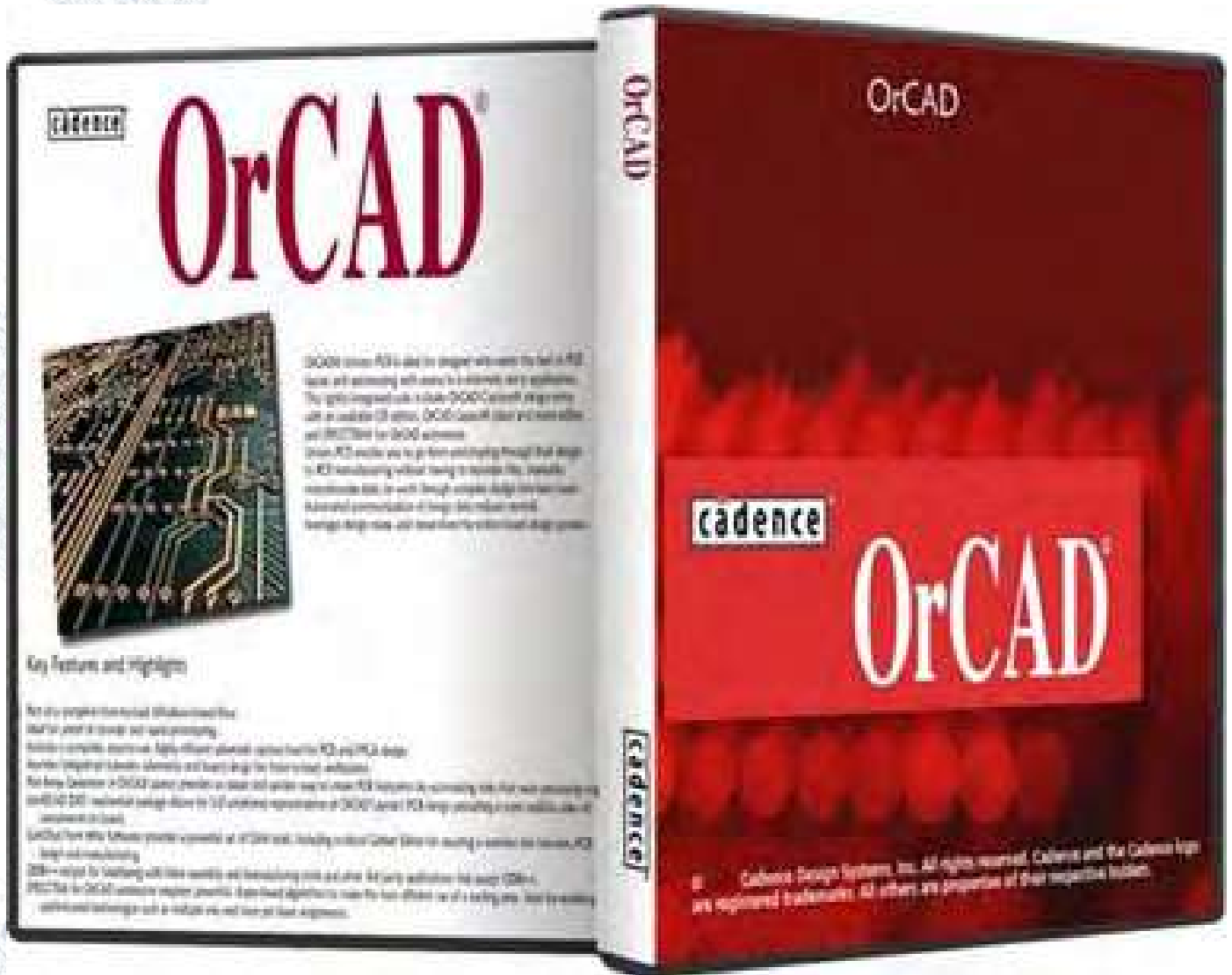

OrCAD is a proprietary software tool suite used primarily for electronic design automation. The software is used mainly by electronic design engineers and electronic technicians to create electronic schematics and electronic prints for manufacturing printed circuit boards. The name OrCAD is a portmanteau, reflecting the company and its software's origins:

Oregon + CAD

4.1 OrCAD

The Cadence OrCAD product line provides affordable, high-performance PCB design tools that boost productivity for smaller design teams and individual PCB designers.

4.1.1 PCB DESIGNING

PCB stands for “PRINTED CIRCUIT BOARD”. Printed circuit board (PCB) provides both the physical structure for mounting and holding the components as well as the electrical interconnection between the components. That means a PCB or PWB (printed wiring board) is the platform upon which electronic components such as integrated circuit chips and other components are mounted. A PCB consists of a nonconducting substrate (typically fibre glass with epoxy as resin) upon which the conductive pattern or circuitry is formed. Copper is the most prevalent conductor although nickel, silver and tin are also used in some cases.



Fig: 4.1.1 Types Of OrCAD

OrCad has a long history of providing individuals and teams with a complete set of technologies that offer unprecedented productivity, seamless tool integration, and exceptional value. New 10.5 release continues that tradition. Today's lower cost and yet highly sophisticated electronic design automation systems have created a unique challenge to nearly every engineering department. Therefore the use of EDA tools has become increasingly important as product life cycles have become shorter and shorter.

Modern electronic design automation (EDA) tools are beginning to support a more efficient and integrated approach to electronic. OrCad Capture® design entry is the most widely used schematic entry system in electronic design today for one simple reason: fast and universal design entry. Whether you're designing a new analog circuit, revising schematic diagram for an existing PCB, or designing a digital block diagram with an HDL module, OrCad Capture provides simple schematic commands you need to enter, modify and verify the design for PCB. OrCad Layout® offers PCB designers and PCB design teams the power and flexibility to create and share PCB data and constraints across the design flow. OrCad Layout delivers all the capabilities to designers need from netlist to place and route, to final output.



4.1.2 LAYOUT PLUS

Shrinking design cycles and a growing number of nets with constraints require customers to adopt PCB design methodologies that increase predictability and accelerate design turnaround. Cadence® layout and routing technology offers a scalable, easy-to-use, constraint-driven PCB design solution for simple to complex PCBs, including those with RF etch components.

Cadence® OrCAD® PCB Designer contains a fully integrated design flow that includes a constraint manager, design capture technology, component tools, a PCB editor, an auto/interactive router, and interfaces for manufacturing and mechanical CAD.

At the heart of OrCAD PCB Designer is OrCAD PCB Editor, an interactive environment for creating and editing simple to complex multi-layer PCBs. The extensive feature set addresses a wide range of design and manufacturability challenges. OrCAD PCB Designer and OrCAD PCB Designer with PSpice both include Cadence SPECCTRA® for OrCAD, the market-leading PCB solution for automatic and interactive interconnect routing.

FEATURES

Offers a proven, scalable, easy-to-use PCB editing and routing solution that grows as needed

Tight, front-to-back application integration increases productivity and ensures data integrity

A comprehensive feature set and a seamless PCB design environment delivers a complete solution to take a design from concept to production

4.1.3 CAPTURE CIS

OrCAD Capture provides fast and intuitive schematic design entry for PCB development or analog simulation using PSpice. The component information system (CIS) integrates with it to automatically synchronize and validate externally sourced part data.

Easy-to-use and powerful, Cadence® OrCAD® Capture is the most widely used schematic design solution, supporting both flat and hierarchal designs from the simplest to the most complex. Seamless bidirectional integration with OrCAD PCB Editor enables data synchronization and cross-probing/placing between the schematic and the board design. OrCAD Capture allows designers to back annotate layout changes, make gate/pin swaps, and change component names or values from board design to schematic using the feedback process. It also comes with a large library of schematic symbols and can export net lists in a wide variety of formats.



CIS allows designers to search, identify, and populate the design with preferred parts. With easy access to company component databases and part information, designers can reduce the amount of time spent researching needed parts.

FEATURES

- Boosts schematic editing efficiency of complex designs through hierarchical and Variant design capabilities.
- Integrates with a robust CIS that promotes the use of preferred, current parts to Accelerate the design process and reduce project costs.
- Provides access to more than two million parts with Cadence Active Parts, Offering greater flexibility when choosing design components.

4.2 PIC BURNER

This is the ultimate PIC/EEPROM programmer! The internet is full of PIC programmer software. The problem is that most of the programmers support only one type of hardware and only one operating system.

PIC Burner is very versatile software. We can use different kinds of hardware with it, because the pins used on parallel port can be set using a simple ini-file. We can also use different assemblers, because pburn can read all kinds of Intel hex file formats used (inhx32, inhx16 and inhx8m).

FEATURES

- Linux and Windows XP/Vista/7 support
- Parallel port hardware support
- Program memory and configuration memory read/write/verify
- Data memory read/write/verify
- Reads and writes multiple hex file formats (inhx32, inhx16, inhx8m)
- Input file format auto detection
- Good documentation
- Support for serial port hardware

4.3 MIKRO C (COMPILER)

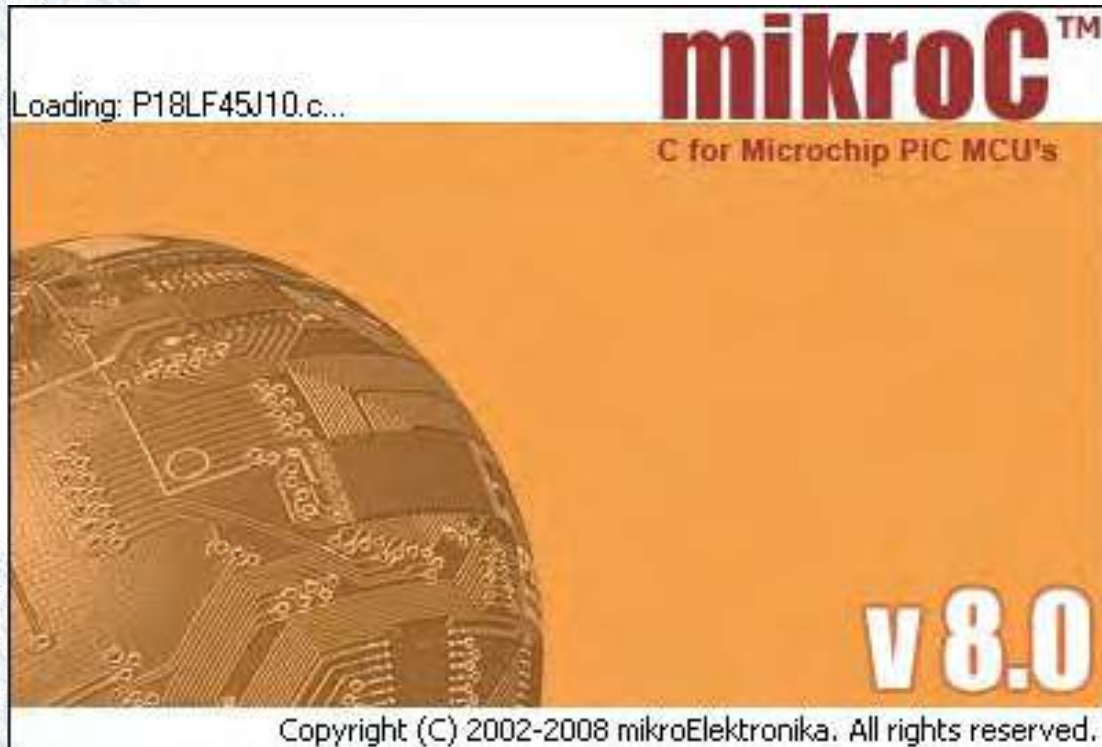

4.3.1 INTRODUCTION TO MIKRO C

MikroC is a powerful, feature rich development tool for PICmicros. It is designed to provide the programmer with the easiest possible solution for developing applications for embedded systems, without compromising performance or control. PIC and C fit together well: PIC is the most popular 8-bit chip in the world, used in a wide variety of applications, and C, prized for its efficiency, is the natural choice for developing embedded systems. mikroC provides a successful match featuring highly advanced IDE, ANSI compliant compiler, broad set of hardware libraries, comprehensive documentation, and plenty of ready-to-run examples.

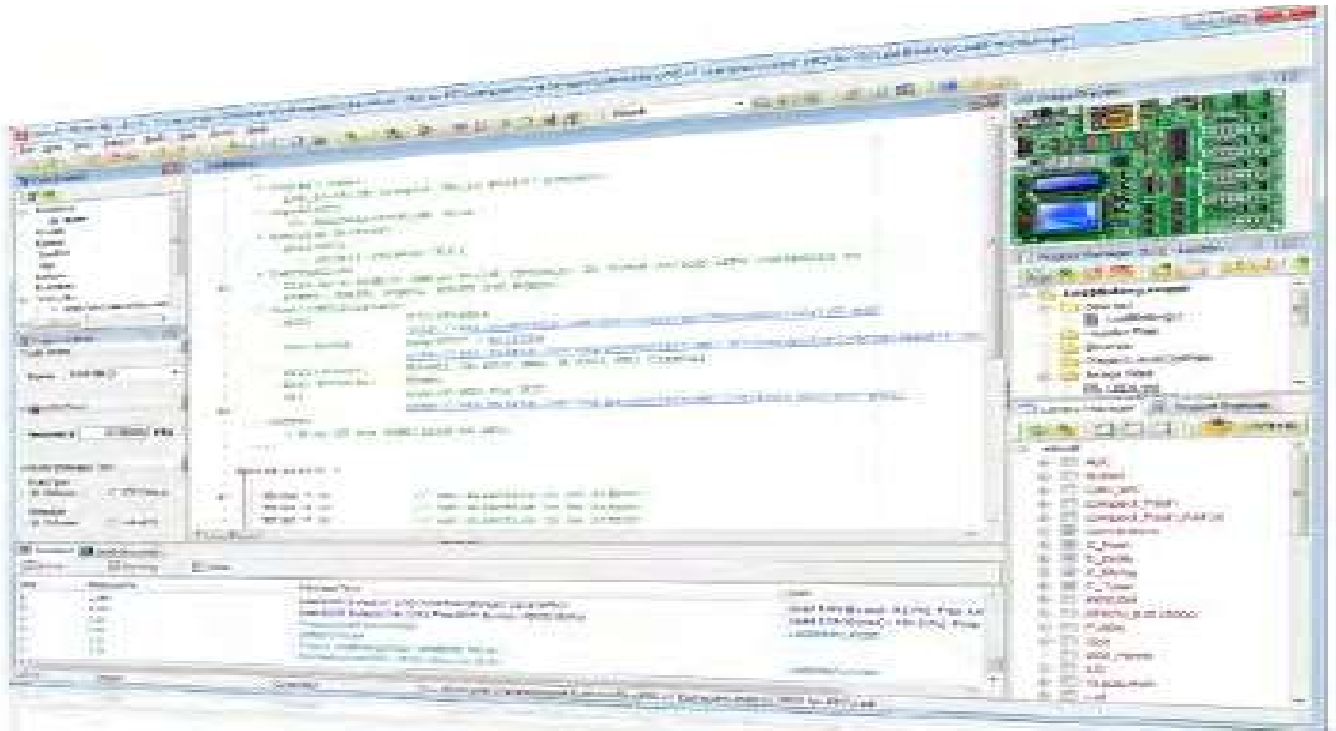

Fig: 4.3.1 A Still Of MikroC

FEATURES

mikroC allows you to quickly develop and deploy complex applications:

- Write your C source code using the built-in Code Editor (Code and Parameter Assistants, Syntax Highlighting, Auto Correct, Code Templates, and more...)
- Use the included mikroC libraries to dramatically speed up the development: data Acquisition, memory, displays, conversions, communications
- Monitor your program structure, variables, and functions in the Code Explorer.
- Generate commented, human-readable assembly, and standard HEX compatible with all programmers.
- Inspect program flow and debug executable logic with the integrated Debugger.
- Get detailed reports and graphs: RAM and ROM map, code statistics, assembly Listing, calling tree, and more...
- We have provided plenty of examples for you to expand, develop, and use as Building bricks in your projects. Copy them entirely if you deem fit

4.3.2 PROJECTS

mikroC organizes applications into projects, consisting of a single project file (extension .ppc) and one or more source files (extension .c). You can compile source files only if they are part of a project.

The project file carries the following information:

- project name and optional description,
- target device,
- device flags (config word),
- device clock,

4.4 USB PIC BOOTLOADER (PIC-BOOT)

A bootloader is a program that stays in the micro controller and communicates with the PC (usually through the serial interface). The bootloader receives a user program from the PC and writes it in the flash memory, then launches this program in execution. Bootloaders can only be used with those micro controllers that can write their flash memory through software as PIC16F870.

USB PIC Bootloader is a resident bootloader for PIC18 series of Enhanced Flash USB Micro controllers. It allows us to program a new firmware application image into the chip using the standard USB connectivity of your device.

- USB PIC Bootloader fully complies with USB Specification for Human Input Devices (HID) and all interfacing is done via standard HID driver from Microsoft.
- XTEA encryption algorithm is used to protect privacy of firmware application updated With USB PIC Bootloader.
- USB PIC Bootloader code is write-protected and cannot be overwritten by firmware.
- Firmware update or user mode is selected by SW and/or HW switch.
- USB PIC Bootloader is a small program that stays in the first 2,048 bytes of the program memory of the Microchip PIC Micro controller.
- Bootloader runs at the boot time (when the processor has just been reset) and is Capable of loading a complete application program into a processor's memory.
- With the USB PIC Bootloader loaded, there are two distinct modes of operation: Firmware update mode and user mode.
- USB PIC Bootloader uses the EEPROM mark and/or hardware switch to determine which mode to run in.

The bootloader firmware is given in the form of Basic source program that has to be compiled with PIC Simulator IDE integrated Basic compiler to get the HEX file ready to be programmed into the microcontroller. The correct micro controller model needs to be selected - 16F877(A), and the selected clock frequency is supposed to be at least 8MHz

Since the start address 0000 hex is set for the boot loader software our New start is always 0010 hex. This means that when we write our code must always think that the start is at address 0010 hex.

5. PCB Designing

PCB stands for "PRINTED CIRCUIT BOARD". Printed circuit board (PCB) provides both the physical structure for mounting and holding the components as well as the electrical interconnection between the components. That means a PCB or PWB (printed wiring board) is the platform upon which electronic components such as integrated circuit chips and other components are mounted. A PCB consists of a non-conducting substrate (typically fiber glass with epoxy as resin) upon which the conductive pattern or circuitry is formed. Copper is the most prevalent conductor although nickel, silver and tin are also used in some cases.

5.1 TYPES OF PCB

PCB may be of different types:-

- 1) Single-sided
- 2) Double-sided
- 3) Multilayer

SINGLE SIDED PCBs: - As the name suggest in these designs the conductive pattern is only at in one side. And also the size is large in these case but these are cheap.

DOUBLE SIDED PCBs:-These are the PCBs on which the conductive pattern is in on both sides. The size of board is small in this case but it is costlier than that of above.

MULTILAYER PCBs:- In this case the board consists of alternating layers of conducting pattern and insulating material. The conductive Material is connected across the layers through plated
Through holes.

The size of this PCB is smaller than that of double sided PCB but it is very costly.

PCBs may also be either rigid, flexible, or the combination of two (rigid-flex). When the electronic components have been mounted on the PCB, the combination of PCB and components is an electronic assembly, also called PRINTED CIRCUIT ASSEMBLY. This assembly is the basic building block for all the electronic appliances such as television, computer and other goods.

5.2 FUNCTION OF PCB

Printed circuited boards are dielectric substrates with metallic circuitry formed on that. They are some times referred to as the base line in electronic packaging. Electronic packaging is fundamentally an inter connection technology and the PCB is the baseline building block of this technology.

5.3 TECHNIQUES USED FOR PCB DESIGNING

There mainly two techniques which are use for the PCB designs.

1. Hand Taping
2. Computer Aided Design

5.3.1 PCBs USING HAND TAPING

- o PCB design using hand taping is the process of technical drawing.
- o In hand taping method layout should be prepared on grid paper.
- o In hand taping, components pads can be prepared by using black pads.
- o Routing of the board can be done by tapes with different widths.
- o Each layer (top, bottom) has to prepare separately.

DISADVANTAGES OF HAND-TAPING FOR PCB DESIGNING

- o Each layer has to be designed separately.
- o We cannot generate NCD files for CNC drilling.
- o Difficult to modify the design in the designing process or after designing.
- o Difficult to get good design overview.

5.3.2 PCB DESIGNING USING CAD

All the above difficulties can be removed by using CAB system.

CAD system for PCB designing requires following:

- o A computer system.
- o PCB design software like OrCad, CADSTAR, Protel, TANGO, Mentor etc.
- o A photo plotter for art work generation.

There are many enhanced features in electronics design automation tools which not possible in the hand taping.

THE MAIN ADVANTAGES ARE GIVEN BELOW

- o Auto placement
- o Auto routing
- o After routing, optimization of tracks can be done.
- o Provides physical design reuse modules
- o Electrical rule check (ERC)
- o All the layers are generated from the same design by giving different options.
- o Bill of material can be generated which contains number of different components used.
- o We can draw conductors as an arc, semi-circular at different angles.
- o Design Rule Check
- o Advanced CAD systems have high speed analysis.
- o CAD system provides all NCD files and Gerber data files for photo plotting.

5.3.3 BASIC DESIGN SYSTEM IN CAD

The following design steps are very common while designing a PCD in CAD:

- Entry the schematic diagram.
- Net list file creation.
- Placement of components manually or automatically.
- Routing of the board using manual routing tools or auto router
- Design rule check physical and electrical.
- Artwork generation.

5.3.4 TRADITIONAL DESIGN FLOW IN CAD

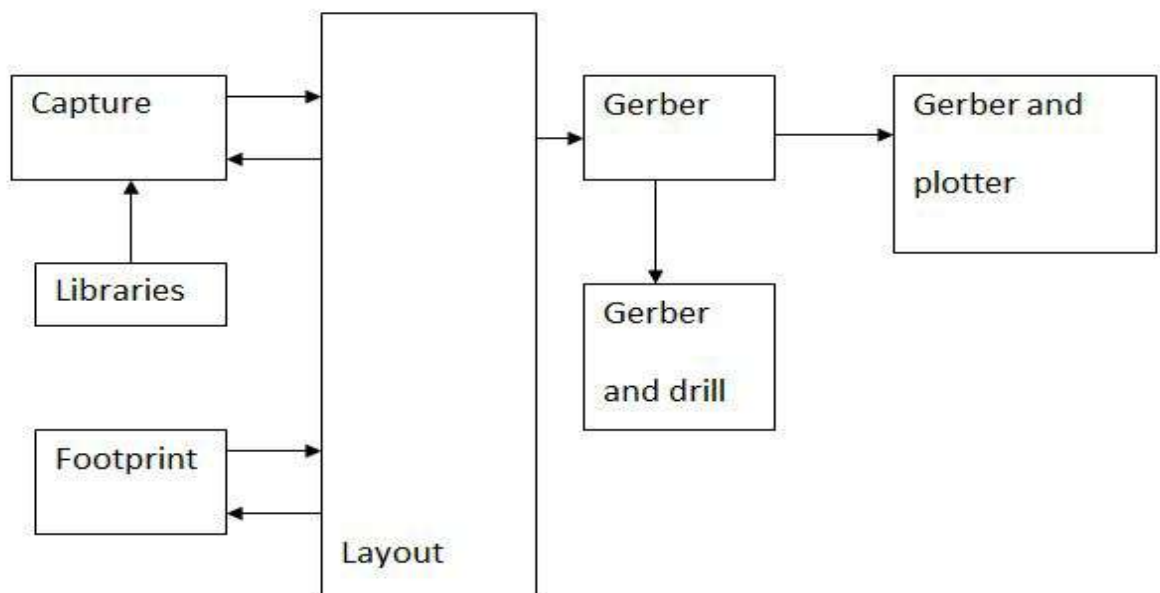

Fig: 5.3.4 The Procedure Of PCB Designing Using OrCAD

5.3.5 DESIGNING SOFTWARES

There many softwares which are used for PCB designs. Some of them are given below:-

- OrCad
- CADSTAR
- Protel
- TANGO
- Mentor

The most commonly software which are used for PCB design in India are Protel and OrCad.

5.4 *OrCAD DESIGN ENVIRONMENT*

OrCad has a long history of providing individuals and teams with a complete set of technologies that offer unprecedented productivity, seamless tool integration, and exceptional value. New 10.5 release continues that tradition.

Today's lower cost and yet highly sophisticated electronic design automation systems have created a unique challenge to nearly every engineering department. Therefore the use of EDA tools has become increasingly important as product life cycles have become shorter and shorter. Modern electronic design automation (EDA) tools are beginning to support a more efficient and integrated approach to electronic.

OrCad Capture® design entry is the most widely used schematic entry system in electronic design today for one simple reason: fast and universal design entry. Whether you're designing a new analog circuit, revising schematic diagram for an existing PCB, or designing a digital block diagram with an HDL module, OrCad Capture provides simple schematic commands you need to enter, modify and verify the design for PCB. OrCad Layout® offers PCB designers and PCB design teams the power and flexibility to create and share PCB data and constraints across the design flow.

OrCad Layout delivers all the capabilities to designers need from netlist to place and route, to final output. The ease-of use and intuitive capabilities of OrCad Layout provides for quick startup and rapid learning right out of the box.

5.4.1 *PCB DESIGN STEPS IN OrCAD 10.5*

Entry of Schematic Diagram

Schematic diagram provides the functional flow and the graphical representation of an electronic circuit. The entry of schematic diagram is the first step in PCB design using OrCad.

A schematic diagram consists of:-

- Electrical connections(nets)
- Junctions
- Integrated circuits symbols
- Discrete components symbols like resistors, capacitors etc.
- Input / output connectors
- Power and ground symbols
- Buses
- No connection symbols
- Components reference names
- Text

5.4.2 THE SCHEMATIC PAGE EDITOR

The schematic page editor is used to display and edit schematic pages. So that one can parts; wires; buses and draw graphics. The schematic page editor has a tool palette that you can use to draw and place everything you need to create a schematic page. One can print from within the schematic page editor, or from the project window.

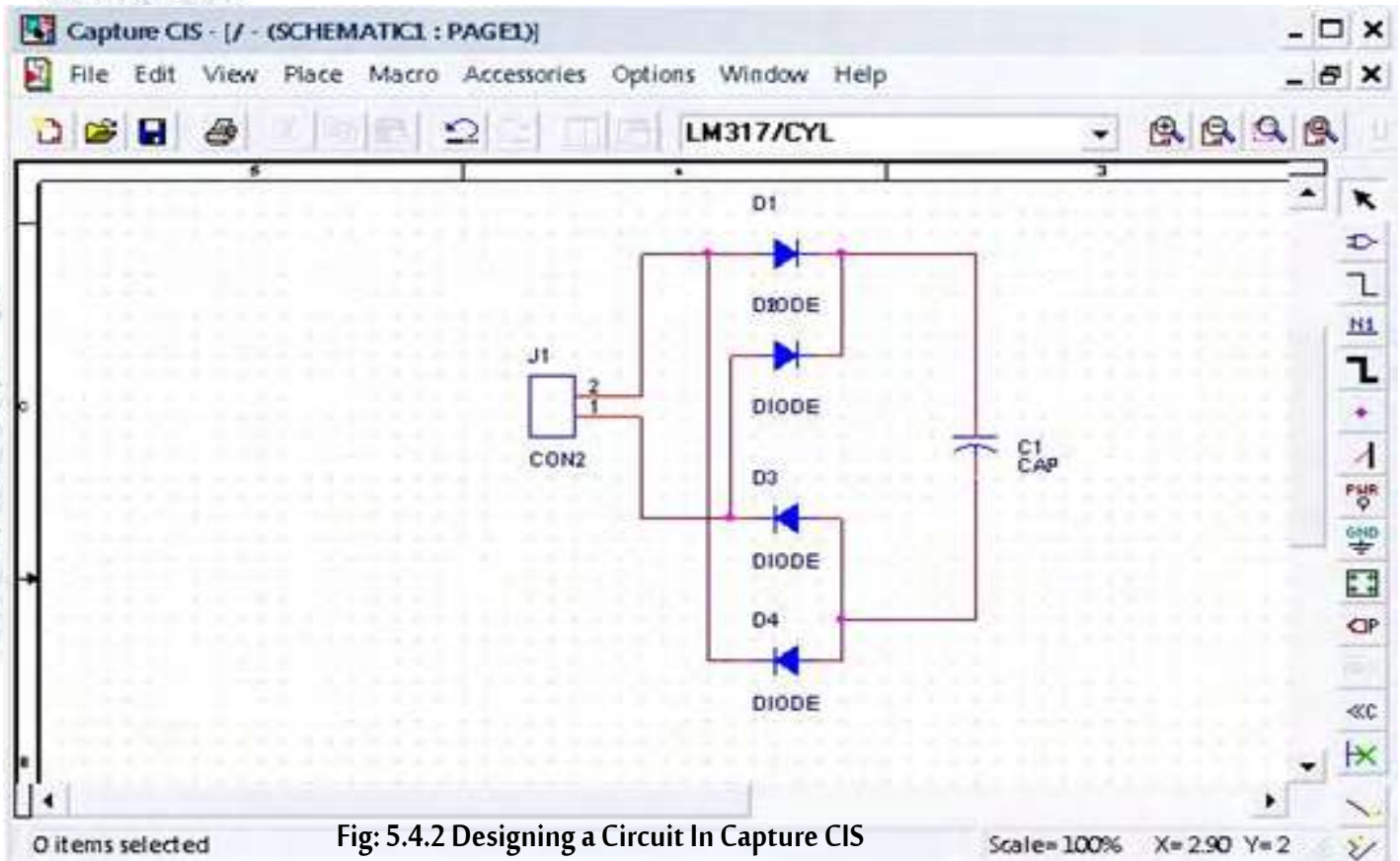

5.4.3 THE PART EDITOR

The part editor is used to create and edit parts.

From the view menu of the part editor you can choose either part or package. In part view one can:-

- Create and edit parts and symbols, then store in new or existing libraries.
- Create and edit power and ground symbols, off-page connector symbols, and title block
- Use the tool palette's electrical tools to place pins on parts, and its drawing tools to draw parts and symbols.

One can search for information in the session log using the find command on the Edit menu. You can also save the contents of the of the session log to a file, which is useful when working with OrCAD's technical support to solve technical problems. The default filename is SESSION.TXT

5.4.4 CREATING NET LIST FILE

Net-list file is a document file which contains information about the logical interconnections between signals and pins. Before one create a net list file, be sure one's project is completed, annotated and it is free from electrical rule violations.

A net list file consists of nets, components, connectors, junctions, no connection symbol, power and ground symbols.

Creation of net list in capture:

- Select your design in the project manager.
- From the tools, choose create net list. The net list dialog box displays.
- Choose a net list format tab.
- If necessary, set the part value and PCB foot print combined property strings to Reflect the information you want in the net list.
- Click OK to create the net list.
- In the net list file text box, enter a name for the output file. If the selected format creates an additional file, enter its file name in the second text box.

5.5 PLACEMENTS OF LAYOUT PLUS:

5.5.1 WHAT IS LAYOUT PLUS ?

Layout plus is one part for the PCB design in which we place as well as route the components an set unit of measurement, grids, and spacing in OrCad. Within other soft wares you also have to place and route the components in similar way. For the placement and routing of the components we normally use auto-placement and auto-routing. Unfortunately, in a lot of soft wares some critical signals have to be routed manually before auto-routing. In layout plus we also define the layer stacks, pad stacks and via's.

5.5.2 STEPS FOR BOARD DESIGN

- At first, we have created a net list from our schematic diagram by using capture.
- Layout plus includes design rules in order to guide logical placement and routing. That means, load the net list into layout to create the board.
- Specify board parameters: Specifying global setting for the board, including nits of Measurements, grid, and spacing
- Place components: Use the components tool in order to place manually the Components which are fixed by the system designer on the board or otherwise use Auto-placement.
- Route the board: Use different routing technologies to route the board and take Advantage of push and shove (a routing technology), which moves track you are Currently routing as well as you can also auto route the board.
- Provide finishing of the board: Layout supplies an ordered progression of commands on the auto menu for finishing your design. These commands include design rule check, cleanup design, rename components, back annotate, run post processor, and create reports.

5.5.3 METHOD TO CREATE A BOARD WITH LAYOUT PLUS

- Ensure that net list with all footprints and necessary information has been created.
- Create a directory in which the schematic design, net list, and board will co-exist and put the schematic design and net list. OrCad provides a directory for this purpose.
- From the layout session frame's file menu, choose New. The load template file in the dialog box displayed.

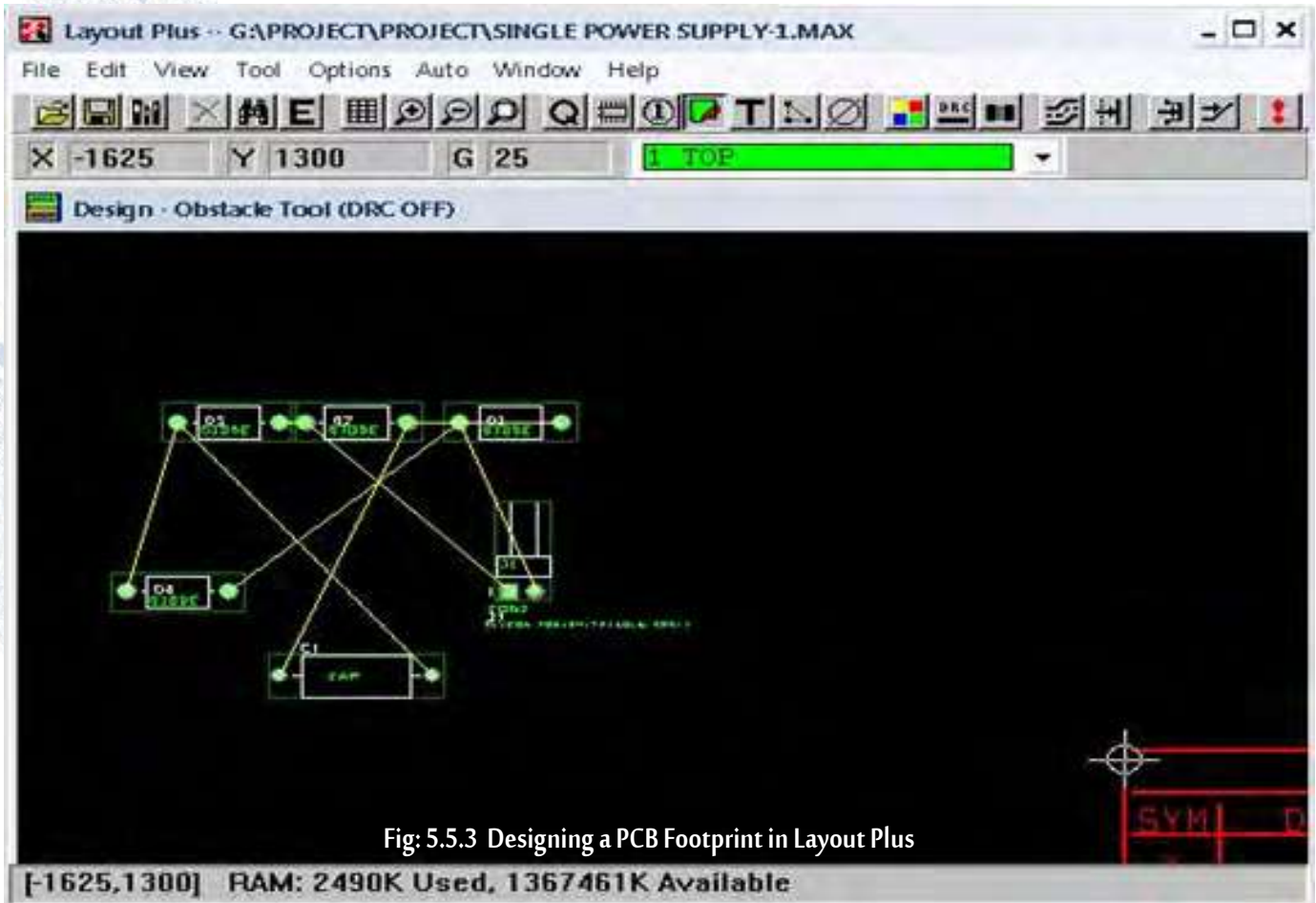

Fig: 5.5.3 Designing a PCB Footprint in Layout Plus

5.5.4 PLACEMENT OF COMPONENTS:

Placement of components means that to place the components in designed box. A designer should follow the following steps before going for it:-

- Optimize the board for component placement.
- Load the placement strategy file.
- Place components on the board.
- Optimize placement using various placements

Components can be placed by using two techniques:-

- 1) Manual placement of components
- 2) Auto placement of components

Choose the components tool bar button. From the pop up men, choose the queue for placement. The components selection criteria dialog box appears. Enter the reference designator of the components that you want to place in the appropriate text box, and click ok. Drag the components to desired location, place it there.

6. Technology To Be Used

The Technology of Any Project is Considered as The Heart as well as The Mind To It. The Biggest Concern To Any Student Or Trainee Remains That The Technology He's Gonna Learn Must Be Up-to-Date and Must to be In Industry's Interest. So, That's Why I've Choose PIC Series Of Microcontrollers. They are Cost Effective, Provide Wide Availability, large user base, extensive collection of application notes, availability of low cost or free development tools, and serial programming (and re-programming with flash memory) capability.

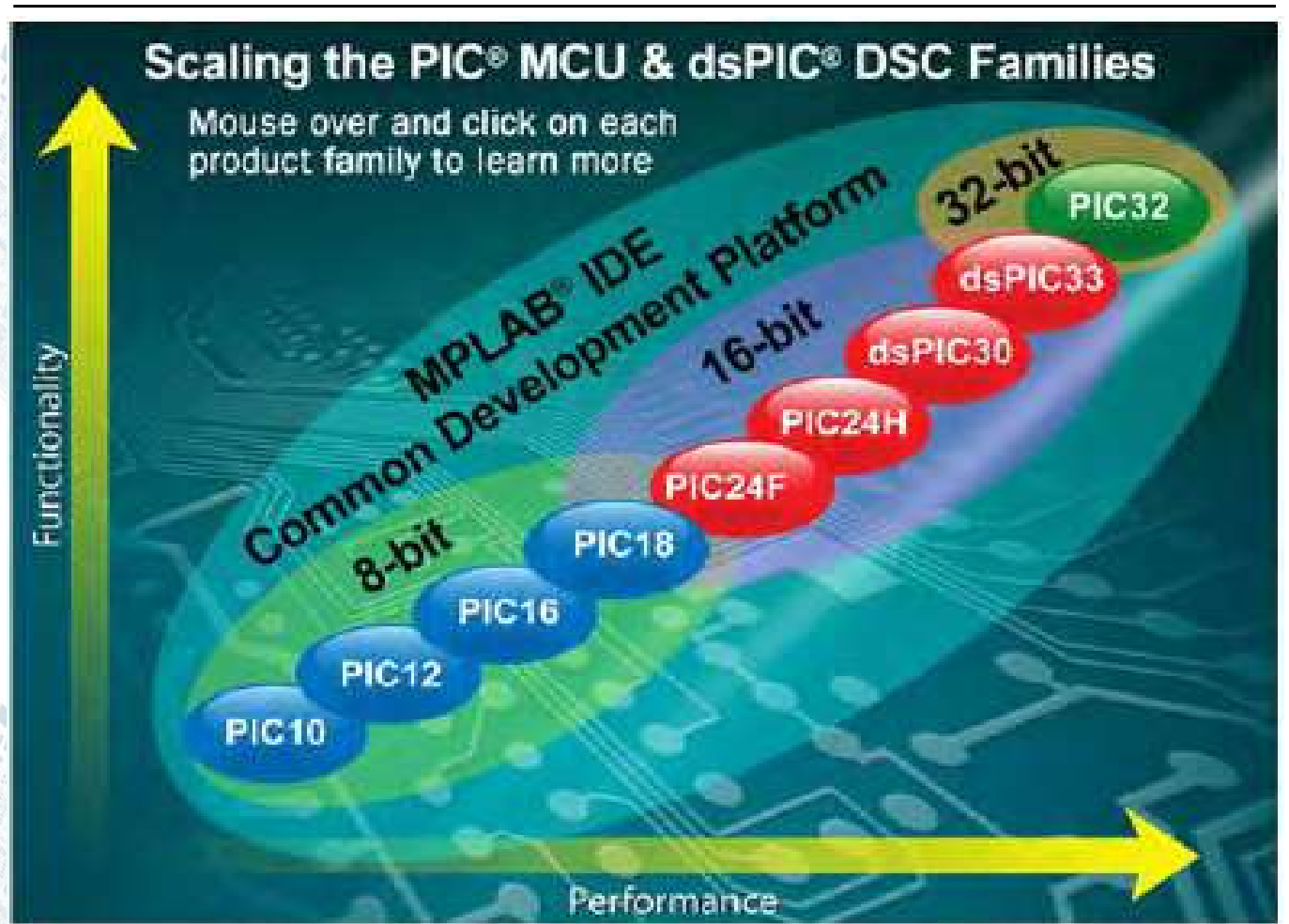

Fig: 6 Various PIC Microcontrollers Offered By Microchip

The Microchip 16C84 (PIC16x84), introduced in 1993, was the first Microchip CPU with on-chip EEPROM memory. This electrically erasable memory made it cost less than CPUs that required a quartz "Erase window" for erasing EPROM.

It is generally thought that PIC stands for Peripheral Interface Controller, although General Instruments' original acronym for the initial PIC1640 and PIC1650 devices was "Programmable Interface Controller". The acronym was quickly replaced with "Programmable Intelligent Computer".

PIC 16 SERIES-PIC16F73

PIC16F73/76 devices are available only in 28-pin packages, while PIC16F74/77 devices are available in 40-pin and 44-pin packages. All devices in the PIC16F7X family share common architecture, with the following differences:

- The PIC16F73 and PIC16F76 have one-half of the total on-chip memory of the PIC16F74 and PIC16F77.
- The 28-pin devices have 3 I/O ports, while the 40/44-pin devices have 5.
- The 28-pin devices have 11 interrupts, while the 40/44-pin devices have 12.
- The 28-pin devices have 5 A/D input channels, while the 40/44-pin devices have 8.
- The Parallel Slave Port is implemented only on the 40/44-pin devices.

6.1 INTRODUCTION

PIC is a family of Harvard architecture microcontrollers made by Microchip Technology, derived from the PIC1640 originally developed by General Instrument's Microelectronics Division. The name PIC initially referred to "**PERIPHERAL INTERFACE CONTROLLER**"

PICs are popular with developers and hobbyists alike due to their low cost, wide availability, large user base, extensive collection of application notes, availability of low cost or free development tools, and serial programming (and re-programming with flash memory) capability.

6.2 SPECIAL MICROCONTROLLER FEATURES:

- High performance RISC CPU.
 - Only 35 single word instructions to learn.
 - All single cycle instructions except for program branches which are two-cycle.
1. Operating speed:DC - 20 MHz clock input DC - 200ns instruction cycle.
 2. Up to 8K x 14 words of FLASH Program Memory, Up to 368 x 8 bytes of Data Memory (RAM).
 3. Interrupt capability (up to 12 sources).
 4. Eight level deep hardware stack.
 5. Direct, Indirect and Relative Addressing modes.
 6. Processor read access to program memory.
 7. Power-on Reset (POR).
 8. Power-up Timer (PWRT) and Oscillator Start-up Timer (OST).
 9. Watchdog Timer (WDT) with its own on-chip RC oscillator for reliable operation.
 10. Programmable code protection.
 11. Power saving SLEEP mode.
 12. Selectable oscillator options.
 13. In-Circuit Serial Programming(ICSP) via two pins.

6.3 PERIPHERAL FEATURES:

- a. Timer0: 8-bit timer/counter with 8-bit prescaler.
- b. Timer1: 16-bit timer/counter with prescaler, can be incremented during SLEEP via external crystal/clock.
- c. Timer2: 8-bit timer/counter with 8-bit period register, prescaler and post Scaler.
- d. Two Capture, Compare, PWM modules:
 - i. Capture is 16-bit, max. Resolution is 12.5 ns
 - ii. Compare is 16-bit, max. Resolution is 200 ns
 - iii. PWM max. resolution is 10-bit.
- e. 8-bit, up to 8-channel Analog-to-Digital converter.
- f. Synchronous Serial Port (SSP) with SPI (Master mode) and I2C(Slave).
- g. Universal Synchronous Asynchronous Receiver Transmitter (USART/SCI).
- h. Parallel Slave Port (PSP), 8-bits wide with external RD, WR and CS controls (40/44-pin only).
- i. Brown-out detection circuitry for Brown-out Reset (BOR).

6.4 CMOS TECHNOLOGY:

- a. Low power, high speed CMOS FLASH technology.
- b. Fully static design.
- c. Wide operating voltage range: 2.0V to 5.5V.
- d. High Sink/Source Current: 25 mA.
- e. Industrial temperature range.
- f. Low power consumption:
- i. < 2 mA typical @ 5V, 4 MHz

6.5 DATA SPACE (RAM)

PICs have a set of registers that function as general purpose RAM. Special purpose control registers for on-chip hardware resources are also mapped into the data space. The addressability of memory varies depending on device series, and all PIC devices have some banking mechanism to extend addressing to additional memory. Later series of devices feature move instructions which can cover the whole addressable space, independent of the selected bank. In earlier devices, any register move had to be achieved via the accumulator.

To implement indirect addressing, a "file select register" (FSR) and "indirect register" (INDF) are used. A register number is written to the FSR, after which reads from or writes to INDF will actually be to or from the register pointed to by FSR. Later devices extended this concept with post- and pre- increment/decrement for greater efficiency in accessing sequentially stored data. This also allows FSR to be treated almost like a stack pointer (SP).

6.6 PIN DIAGRAM

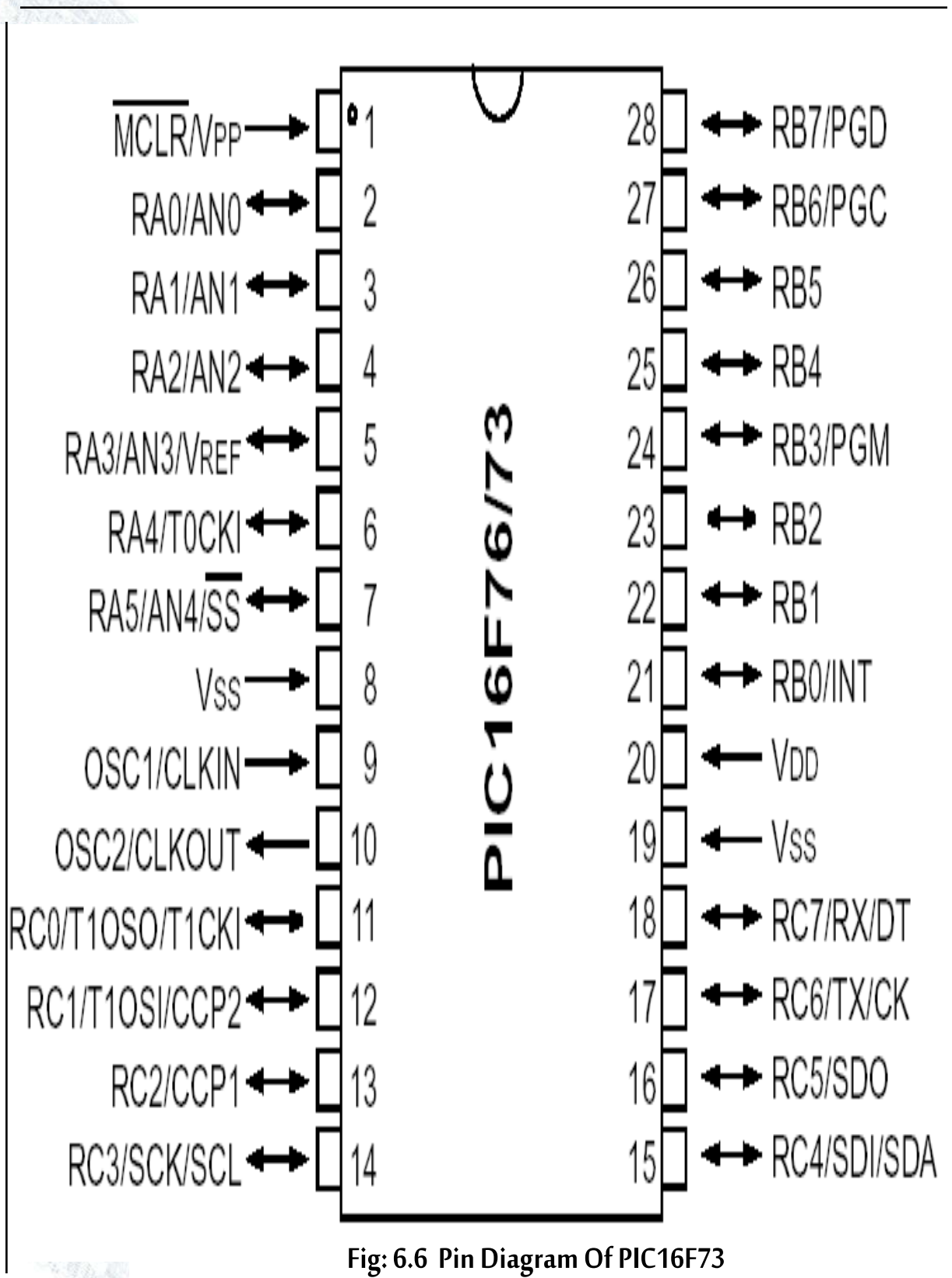

Fig: 6.6 Pin Diagram Of PIC16F73

6.6.1 *PIN DESCRIPTION*

(••) MCLR-(pin 1)

PIC16F7X devices have a noise filter in the MCLR Reset path. The filter will detect and ignore small pulses. It should be noted that a WDT Reset does not drive MCLR pin low. The behaviour of the ESD protection on the MCLR pin has been altered from previous devices of this family. Voltages applied to the pin that exceed its specification can result in both MCLR Resets and excessive current beyond the device specification during the ESD event. For this reason, Microchip recommends that the MCLR pin no longer be tied directly to VDD.

(••) RESET

The PIC16F7X differentiates between various kinds of RESET:

- Power-on Reset (POR)
- MCLR Reset during normal operation
- MCLR Reset during SLEEP
- WDT Reset (during normal operation)
- WDT Wake-up (during SLEEP)
- Brown-out Reset (BOR)

Some registers are not affected in any RESET condition. Their status is unknown on POR and unchanged in any other RESET. Most other registers are reset to a "RESET state" on Power-on Reset (POR), on the MCLR and WDT Reset, on MCLR Reset during SLEEP, and Brown-out Reset (BOR). They are not affected by a WDT Wake-up, which is viewed as the resumption of normal operation. The TO and PD bits are set or cleared differently in different RESET situations, as indicated

(••) PORTA –(pin 2 to 7)and the TRISA Register

PORTA is a 6-bit wide, bi-directional port. The corresponding data direction register is TRISA. Setting a TRISA bit (= '1') will make the corresponding PORTA pin an input (i.e., Put the corresponding output driver in a Hi-Impedance mode). Clearing a TRISA bit (= '0') will make the corresponding PORTA pin an output (i.e., put the contents of the output latch on the selected pin).

Reading the PORTA register reads the status of the pins, whereas writing to it will write to the port latch. All write operations are read-modify-write operations. Therefore, a write to a port implies that the port pins are read, the value is modified and then written to the port data latch.

(••) GND –(pin 8)

Provide Ground to it.

(••) OSC1/CLK IN -(pin 9)

Oscillator crystal input/external clock source input.

(••) OSC2/CLK OUT-(pin 10)

Oscillator crystal output. Connects to crystal or resonator in Crystal Oscillator mode. In RC mode, the OSC2 pin outputs CLK OUT which has 1/4 the frequency of OSC1, and denotes the instruction cycle rate.

OSCILLATOR TYPE:

The PIC16F7X can be operated in four different oscillator modes:

- LP Low Power Crystal
- XT Crystal/Resonator
- HS High Speed Crystal/Resonator
- RC Resistor/Capacitor

(••) PORTC and the TRISC Register(pin 11 to 18)

PORTC is an 8-bit wide, bi-directional port. The corresponding data direction register is TRISC. Setting a TRISC bit (= '1') will make the corresponding PORTC pin an input (i.e., put the corresponding output driver in a Hi-Impedance mode). Clearing a TRISC bit (= '0') will

make the corresponding PORTC pin an output (i.e., put the contents of the output latch on the selected pin).

PORTC is multiplexed with several peripheral functions PORTC pins have Schmitt Trigger input buffers. When enabling peripheral functions, care should be taken in defining TRIS bits for each PORTC pin.

(••) Vss(pin 19)

Ground reference for logic and I/O pins

(••) Vdd(pin 20)

Positive supply for logic and I/O pins

(••) PORTB and The TRISB Register(pin 21 to 28)

PORTB is an 8-bit wide, bi-directional port. The corresponding data direction register is TRISB. Setting a TRISB bit (= '1') will make the corresponding PORTB pin an input (i.e., put the corresponding output driver in a Hi-Impedance mode). Clearing a TRISB bit (= '0') will make the corresponding PORTB pin an output (i.e., Put the contents of the output latch on the selected pin).

Each of the PORTB pins has a weak internal pull-up. A single control bit can turn on all the pull-ups. The weak pull-up is automatically turned off when the port pin is configured as an output. The pull-ups are disabled on a Power-on Reset.

6.6.2 FEATURE TABLE OF PIC16F73

Key Features	PIC16F73
Operating Frequency	DC - 20 MHz
RESETS (and Delays)	POR, BOR (PWRT, OST)
FLASH Program Memory (14-bit words)	4K
Data Memory (bytes)	192
Interrupts	11
I/O Ports	Ports A,B,C
Timers	3
Capture/Compare/PWM Modules	2
Serial Communications	SSP, USART
Parallel Communications	—
8-bit Analog-to-Digital Module	5 Input Channels
Instruction Set	35 Instructions
Packaging	28-pin DIP 28-pin SOIC 28-pin SSOP 28-pin MLF

Fig: 6.6.2 Feature Table Of PIC16F73

6.7 MEMORY ORGANIZATION

There are two memory blocks in each of these PICmicro® MCUs. The Program Memory and Data Memory have separate buses so that concurrent access can occur and is detailed in this section. The Program Memory can be read internally by user code.

Additional information on device memory may be found in the PICmicro Mid-Range Reference Manual.

6.8 CORE ARCHITECTURE

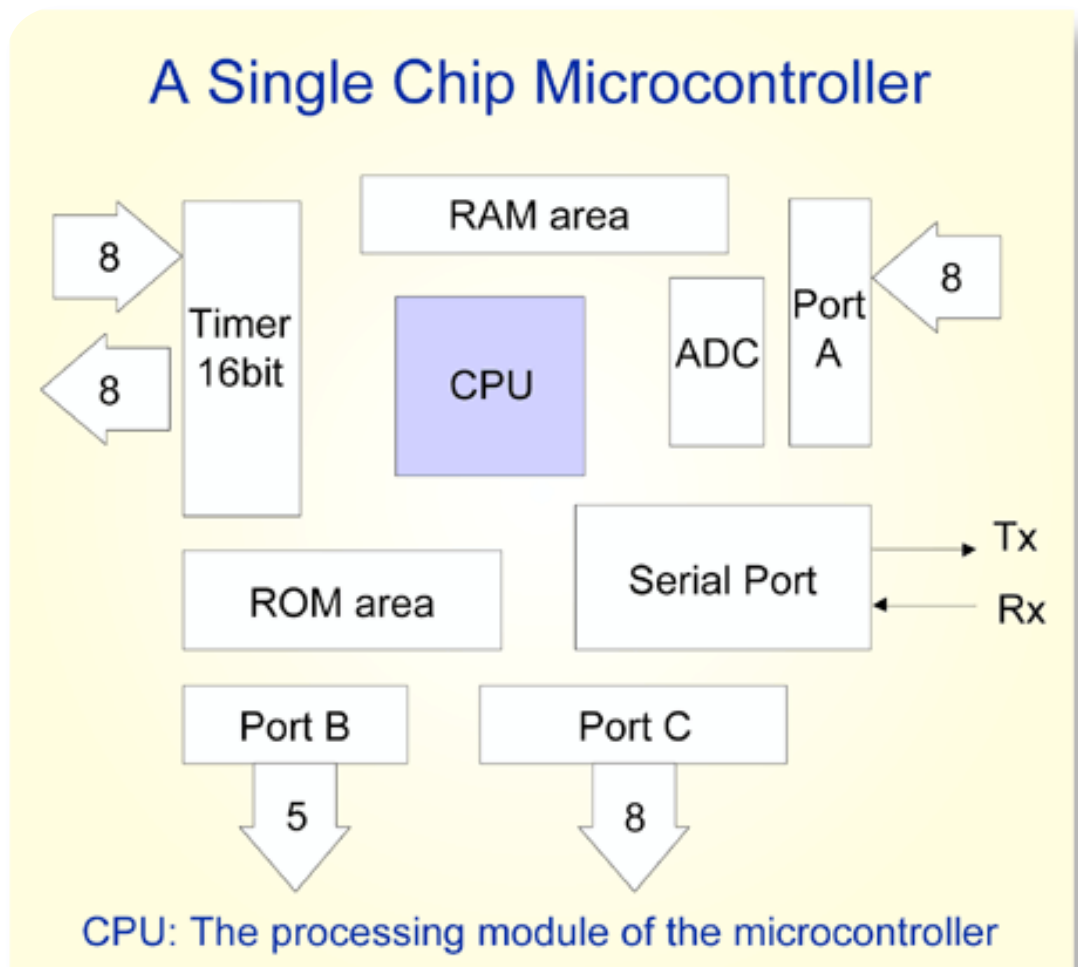

Fig: 6.8 Flowchart Showing a typical microcontroller device and its different sub-Units

The PIC architecture is distinctively minimalist. It is characterized by the following features:

- Separate code and data spaces (Harvard architecture)
- A small number of fixed length instructions
- Most instructions are single cycle execution (4 clock cycles), with single delay cycles upon branches and skips
- A single accumulator (W), the use of which (as source operand) is implied (i.e. is not encoded in the opcode)
- All RAM locations function as registers as both source and/or destination of math and other functions.
- A hardware stack for storing return addresses
- A fairly small amount of addressable data space (typically 256 bytes), Extended through banking
- Data space mapped CPU, port, and peripheral registers
- The program counter is also mapped into the data space and writable (this is used to implement indirect jumps).

Unlike most other CPUs, there is no distinction between memory space and register space because the RAM serves the job of both memory and registers, and the RAM is usually just referred to as the register file or simply as the registers.

ADVANTAGES

The PIC architectures have these advantages:

- Small instruction set to learn.
- RISC architecture.
- Built in oscillator with selectable speeds.
- Easy entry level, in circuit programming plus in circuit debugging.
- PICKit units available from Microchip.com for less than \$50.
- Inexpensive microcontrollers.
- Wide range of interfaces including I²C, SPI, USB, USART, A/D, programmable comparators, PWM, LIN, CAN, PSP, and Ethernet.

6.9 UNIVERSAL SYNCHRONOUS ASYNCHRONOUS RECEIVER & TRANSMITTER (USART)

The Universal Synchronous Asynchronous Receiver Transmitter (USART) module is one of the two serial I/O modules. (USART is also known as a Serial Communications Interface or SCI.) The USART can be configured as a full duplex asynchronous system that can communicate with peripheral devices, such as CRT terminals and personal computers, or it can be configured as a half duplex synchronous system that can communicate with peripheral devices, such as A/D or D/A integrated circuits, serial EEPROMs, etc.

THE USART CAN BE CONFIGURED IN THE FOLLOWING MODES

- Asynchronous (full duplex)
- Synchronous - Master (half duplex)
- Synchronous - Slave (half duplex)

Bit SPEN (RCSTA<7>) and bits TRISC<7:6> have to be set in order to configure pins RC6/TX/CK and RC7/RX/DT as the Universal Synchronous Asynchronous Receiver Transmitter.

6.9.1 PIC16F73 VOLTAGE-FREQUENCY GRAPH

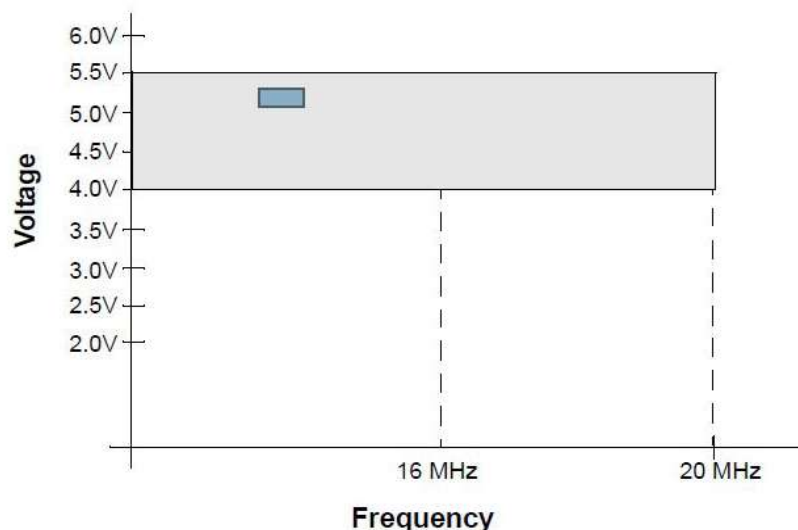

Fig: 6.9.1 The V-F Graph Of PIC

7. Project Planning

7.1 PROJECT PLANNING & SCHEDULING

The planning stage establishes a bird's eye view of the intended software product, and uses this to establish the basic project structure, evaluate feasibility and risks associated with the project, and describe appropriate management and technical approaches.

Project planning is part of Project Management. It is a well-established approach to managing and controlling the introduction of new initiatives or organisational changes. Projects are finite in length, usually one-time pieces of work involving a number of activities that must be completed within a given time frame, and often on a fixed budget.

While the very simplest projects can be managed easily by applying common sense and just getting on with things, projects that are more complex need a great deal of planning, and benefit from a formal, disciplined management approach. From making sure that activities will actually meet the specified need, to devising a workable schedule, developing systems for reporting progress, and managing requests for changes – all of these issues require thoughtful consideration. Managing projects well requires a great deal of time, skill, and finesse. There are many sides to project management and this is what makes it so interesting and demanding.

7.1.1 PROJECT PLANNING INCLUDES

- Dividing the project into plannable stages
- When to build the project plan
- Who constructs the project plan
- Step by step guide to constructing a project plan
- Making the project plan visible, getting the project plan used
- Independent project plan reviews
- Getting resource commitments
- Time recording
- Tracking progress against the project plan
- Revising the project plan during the project

Now, After The Project Planning I'm Very Interested to Add The List Of The Components That's been Used in the Wireless RF Module Project. So, Here's Gonna Be The Step By Step Listing Of Components Of This Project Under Requirement Analysis.

8. REQUIREMENT ANALYSIS

Requirement Analysis in electronics engineering, encompasses those tasks that go into determining the needs or conditions to meet for a new or altered product, taking account of the possibly conflicting requirements of the various stakeholders, such as beneficiaries or users.

Requirement analysis is critical to the success of a development project. Requirements must be documented, actionable, measurable, testable, related to identified business needs or opportunities, and defined to a level of detail sufficient for system design. Requirements can be functional and non-functional.

Any coherent and reasonable system must have requirements that define what the system is ultimately supposed to do. A requirement is an objective that must be met. Planners cast most requirements in functional terms, leaving design and implementation details to the developers. In this wireless RF Module Project, we implemented this phase of requirements gathering by collecting information from various sources like internet & also by eternal knowledge of our trainees. The requirement of any electronics project must be its components & the circuit diagram created by using OrCAD & an etched PCB.



Conceptually, requirements analysis includes the components used while created this project. Well, the Softwares & a PC with some other stuff (like soldering wire etc.) also come under requirement section but they've been already pasted in 'Tools To Be Used' section, So here's goes the Components list section, named "Listing The Components".!!

8.1 LISTING THE COMPONENTS

8.1.1 COMPONENT

Component is Defined As:

An Artifact That is One of The Individual Parts of Which a Composite Entity is Made Up; Especially a Part That Can be Separated From or Attached To a System. So, With The Help Of This Defination We Can Guess The Importance Of Components In Electronics Projects. Components Are The Working Modules Of Any Project That Makes It a Worth To Work. Here, In This Sub Chapter I'm Going To Write The List Of Components That's Been Used To Make This Project a Worth Device.

8.1.2 PRINTED CIRCUIT BOARD

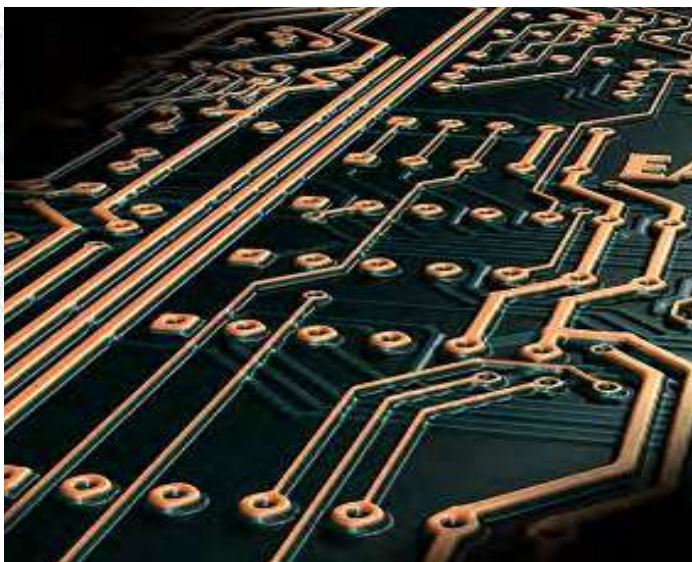

A printed circuit board, or PCB, is used to mechanically support and electrically connect electronic components using conductive pathways, tracks or signal traces etched from copper sheets laminated onto a non-conductive substrate. It is also referred to as printed wiring board (PWB) or etched wiring board. Printed circuit boards are used in virtually all but the simplest commercially produced electronic devices.

A PCB populated with electronic components is called a printed circuit assembly (PCA), printed circuit board assembly or PCB Assembly (PCBA). In informal use the term "PCB" is used both for bare and assembled boards, the context clarifying the meaning.

8.1.3 CAPACITOR

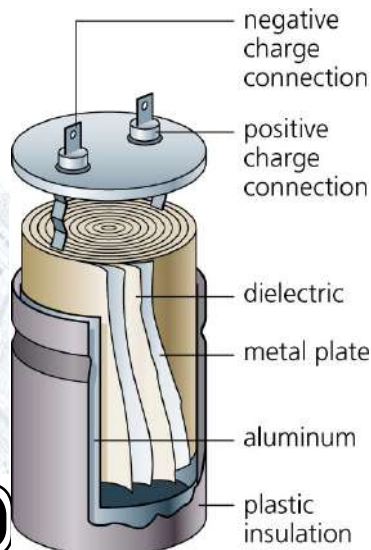

A capacitor (originally known as condenser) is a passive two-terminal electrical component used to store energy in an electric field. The forms of practical capacitors vary widely, but all contain at least two electrical conductors separated by a dielectric (insulator); for example, one common construction consists of metal foils separated by a thin layer of insulating film. Capacitors are widely used as parts of electrical circuits in many common electrical devices.

8.1.4 *LIGHT-EMITTING DIODE*

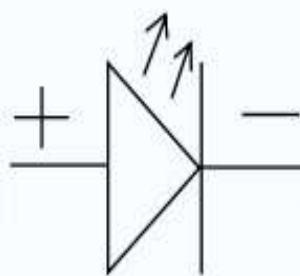
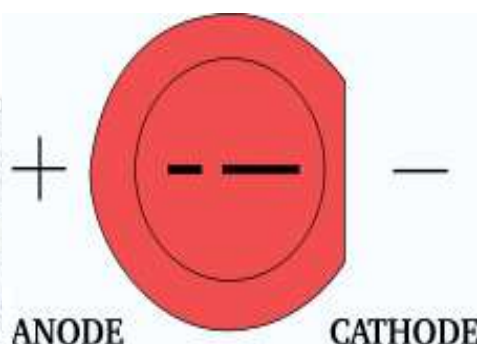

A light-emitting diode (LED) is a semiconductor light source. LEDs are used as indicator lamps in many devices and are increasingly used for other lighting. Introduced as a practical electronic component in 1962, early LEDs emitted low-intensity red light, but modern versions are available across the visible, ultraviolet, and infrared wavelengths, with very high brightness.

When a light-emitting diode is forward-biased (switched on), electrons are able to recombine with electron holes within the device, releasing energy in the form of photons. This effect is called electroluminescent and the colour of the light (corresponding to the energy of the photon) is determined by the energy gap of the semiconductor. LEDs are often small in area (less than 1 mm²), and integrated optical components may be used to shape its radiation pattern. LEDs present many advantages over incandescent light sources including lower energy consumption, longer lifetime, improved robustness, smaller size, and faster switching. LEDs powerful enough for room lighting are relatively expensive and require more precise current and heat management than compact fluorescent lamp sources of comparable output.

8.1.5 *LIQUID CRYSTAL DISPLAY*



Liquid crystal display (LCD) is a flat panel display, electronic visual display, or video display that uses the light modulating properties of liquid crystals (LCs). LCs do not emit light directly.

LCD displays are available to display arbitrary images (as in a general-purpose computer display) or fixed images which can be displayed or hidden, such as preset words, digits, 7-segment displays, etc., as in a digital clock. They use the same basic technology, except that arbitrary images are made up of a large number of small pixels, while other displays have larger elements.

The LCD is more energy efficient and offers safer disposal than a CRT. Its low electrical power consumption enables it to be used in battery-powered electronic equipment. It is an electronically modulated optical device made up of any number of segments filled with liquid crystals and arrayed in front of a light source (backlight) or reflector to produce images in colour or monochrome. Liquid crystals were first developed in 1888.

8.1.6 *RELAY*



A Relay is an electrically operated switch. Many relays use an electromagnet to operate a switching mechanism mechanically, but other operating principles are also used. Relays are used where it is necessary to control a circuit by a low-power signal (with complete electrical isolation between control and controlled circuits), or where several circuits must be controlled by one signal.

A type of relay that can handle the high power required to directly control an electric motor or other loads is called a contactor. Solid-state relays control power circuits with no moving parts, instead using a semiconductor device to perform switching. Relays with calibrated operating characteristics and sometimes multiple operating coils are used to protect electrical circuits from overload or faults; in modern electric power systems these functions are performed by digital instruments still called "protective relays".

8.1.7 *RESISTORS*



A resistor is a passive two-terminal electrical component that implements electrical resistance as a circuit element. The current through a resistor is in direct proportion to the voltage across the resistor's terminals. Thus, the ratio of the voltage applied across a resistor's terminals to the intensity of current through the circuit is called resistance.

Practical resistors have a series inductance and a small parallel capacitance; these specifications can be important in high-frequency applications. In a low-noise amplifier or pre-amp, the noise characteristics of a resistor may be an issue. The unwanted inductance, excess noise, and temperature coefficient are mainly dependent on the technology used in manufacturing the resistor. A family of discrete resistors is also characterized according to its form factor, that is, the size of the device and the position of its leads (or terminals) which is relevant in the practical manufacturing of circuits using them.

8.1.8 *BX R433A*



The BX R433A/433.92/TO39-1.5 is a true one-port, surface-acoustic-wave (SAW) resonator in a low-profile metal TO-39 case. It provides reliable, fundamental-mode, quartz frequency Stabilization i.e. in transmitters or local oscillators operating at 433.920 MHz.

SAW - Surface Acoustic Wave Resonators are being recognized by more and more public figures because of its good features and performances. They have been widely used in communication, CATV, wireless remote control, satellite receivers, radio and video transmission fields.

VTC can supply you high performance, high quality and stability SAW resonators which frequencies cover from 50MHz to 1GHz.

8.1.9 *ULN2801A*



The ULN2801A is a high-voltage, high-current Darlington transistor array. The device consists of eight npn Darlington pairs that feature high-voltage outputs with common-cathode clamp diodes for switching inductive loads. The collector-current rating of each Darlington pair is 500 mA and Output Voltage is upto 50V. The Darlington pairs may be connected in parallel for higher current Capability.

Applications include relay drivers, hammer drivers, lamp drivers, display drivers (LED and gas discharge), line drivers, and logic buffers. The ULN2801A has a 2.7-k Ω series base resistor for each Darlington pair for operation directly with TTL or 5-V CMOS devices.

8.1.10 *BATTERY*



An electrical battery is one or more electrochemical cells that convert stored chemical energy into electrical energy.

There are two types of batteries: primary batteries (disposable batteries), which are designed to be used once and discarded, and secondary batteries (rechargeable batteries), which are designed to be recharged and used multiple times.

8.1.1.1 HT12E/2¹² SERIES OF ENCODER



The 2¹² encoders are a series of CMOS LSIs for remote control system applications. They are capable of encoding information which consists of N address bits and 12N data bits. Each address/ data input can be set to one of the two logic states. The programmed addresses/data are transmitted together with the header bits via an RF or an infrared transmission medium upon receipt of a trigger signal. The capability to select a TE trigger on the HT12E or a DATA trigger on the HT12A further enhances the application flexibility of the 2¹² series of encoders. The HT12A additionally provides a 38kHz carrier for infrared systems.

FEATURES

- Operating voltage
 - 2.4V~5V for the HT12A
 - 2.4V~12V for the HT12E
- Low power and high noise immunity CMOS technology
- Low standby current: 0.1A (type.) at VDD=5V
- HT12A with a 38kHz carrier for infrared transmission medium
- Minimum transmission word
 - Four words for the HT12E
 - One word for the HT12A
- Built-in oscillator needs only 5% resistor
- Data code has positive polarity
- Minimal external components
- HT12A/E: 18-pin DIP/20-pin SOP package

8.1.1.2 HT12D/2¹² SERIES OF DECODERS



The 2¹² decoders are a series of CMOS LSIs for remote control system applications. They are paired with Holtek's 2¹² series of encoders (refer to the encoder/decoder cross reference table). For proper operation, a pair of encoder/decoder with the same number of addresses and data format should be chosen. The decoders receive serial addresses and data from a programmed 2¹² series of encoders that are transmitted by a carrier using an RF or an IR transmission medium. They compare the serial input data three times continuously with their local addresses. If no error or unmatched codes are found, the input data codes are decoded and then transferred to the output pins. The VT pin also goes high to indicate a valid transmission. The 2¹² series of decoders are capable of decoding informations that consist of N bits of address and 12N bits of data. Of this series, the HT12D is arranged to provide 8 address bits and 4 data bits, and HT12F is used to decode 12 bits of address information.

8.1.13 PIC16F73



FEATURES

- 2 PWM 10-bit
- 25mA sink/source per I/O
- 2 Capture/Compare
- Parallel Slave Port

FEATURES

- Operating voltage: 2.4V~12V
- Low power and high noise immunity CMOS Technology
- Low standby current
- Capable of decoding 12 bits of information
- Binary address setting
- Received codes are checked 3 times
- Address/Data number combination
 - HT12D: 8 address bits and 4 data bits
 - HT12F: 12 address bits only
- Built-in oscillator needs only 5% resistor
- Valid transmission indicator
- Easy interface with RF or an infrared transmission Medium
- Minimal external components
- Pair with Holtek's 2¹² series of encoders
- 18-pin DIP, 20-pin SOP package

PIC is a powerful (200 nanosecond instruction execution) yet easy-to-program (only 35 single word instructions) CMOS FLASH-based 8-bit microcontroller packs Microchip's powerful PIC® architecture into 28-pin package and is upwards compatible with the PIC16C5X, PIC12CXXX and PIC16C7X devices. The PIC16F73 features 5 channels of 8-bit Analog-to-Digital (A/D) converter with 2 additional timers, 2 capture/compare/PWM functions and the synchronous serial port can be configured as either 3-wire Serial Peripheral Interface (SPI) or the 2-wire Inter-Integrated Circuit (IC) bus and a Universal Asynchronous Receiver Transmitter (USART). All of these features make it ideal for more advanced level A/D applications in automotive, industrial, appliances and consumer applications.

Parameter Name	Value
Program Memory Type	Flash
Program Memory (KB)	7
CPU Speed (MIPS)	5
RAM Bytes	192
Digital Communication Peripherals	1-A/E/USART, 1-SSP(SPI/I2C)
Capture/Compare/ PWM Peripherals	2 CCP
Timers	2 x 8-bit, 1 x 16-bit
ADC	5 ch, 8-bit
Temperature Range (C)	-40 to 125
Operating Voltage Range (V)	2 to 5.5
Pin Count	28

9. Working Of RF Module

As In The Very First Chapter Of This Report The Introduction has been Pasted. But Now In This Chapter I'm Going To Tell The Operating Functionality Of Wireless Radio Frequency Module Using PIC 16F73.

Before Just Directing to the working of RF Module Let us read about the RF Current & It's Behaviour first.

9.1 SPECIAL PROPERTIES OF RF CURRENT

Electric currents that oscillate at radio frequencies have special properties not shared by direct current or alternating current of lower frequencies. The energy in an RF current can radiate off a conductor into space as electromagnetic waves (radio waves); this is the basis of radio technology. RF current does not penetrate deeply into electrical conductors but flows along their surfaces; this is known as the skin effect. For this reason, when the human body comes in contact with high power RF currents it can cause superficial but serious burns called RF burns. RF current can easily ionize air, creating a conductive path through it.

This property is exploited by "high frequency" units used in electric arc welding, which use currents at higher frequencies than power distribution uses. Another property is the ability to appear to flow through paths that contain insulating material, like the dielectric insulator of a capacitor. When conducted by an ordinary electric cable, RF current has a tendency to reflect from discontinuities in the cable such as connectors and travel back down the cable toward the source, causing a condition called standing waves, so RF current must be carried by specialized types of cable called transmission line.

9.2 MAIN FACTORS AFFECTING RF MODULE'S PERFORMANCE

As with any other radio-frequency device, the performance of an RF Module will depend on a number of factors. For example, by increasing the transmitter power, a larger communication distance will be achieved. However, this will also result in a higher electrical power drain on the transmitter device, which will cause shorter operating life for battery powered devices. Also, using a higher transmit power will make the system more prone to interference with other RF devices, and may in fact possibly cause the device to become illegal depending on the jurisdiction.

Correspondingly, increasing the receiver sensitivity will also increase the effective communication range, but will also potentially cause malfunction due to interference with other RF devices.

9.3 FREQUENCIES CHART

<u>Frequency</u>	<u>Wavelength</u>	<u>Designation</u>	<u>Abbreviation</u> ^[2]
3 – 30 Hz	$10^4 - 10^5$ km	<u>Extremely low frequency</u>	ELF
30 – 300 Hz	$10^3 - 10^4$ km	<u>Super low frequency</u>	SLF
300 – 3000 Hz	$100 - 10^3$ km	<u>Ultra low frequency</u>	ULF
3 – 30 kHz	10 – 100 km	<u>Very low frequency</u>	VLF
30 – 300 kHz	1 – 10 km	<u>Low frequency</u>	LF
300 kHz – 3 MHz	100 m – 1 km	<u>Medium frequency</u>	MF
3 – 30 MHz	10 – 100 m	<u>High frequency</u>	HF
30 – 300 MHz	1 – 10 m	<u>Very high frequency</u>	VHF
300 MHz – 3 GHz	10 cm – 1 m	<u>Ultra high frequency</u>	UHF
3 – 30 GHz	1 – 10 cm	<u>Super high frequency</u>	SHF
30 – 300 GHz	1 mm – 1 cm	<u>Extremely high frequency</u>	EHF

Fig: 9.3 Frequencies Table Of RF

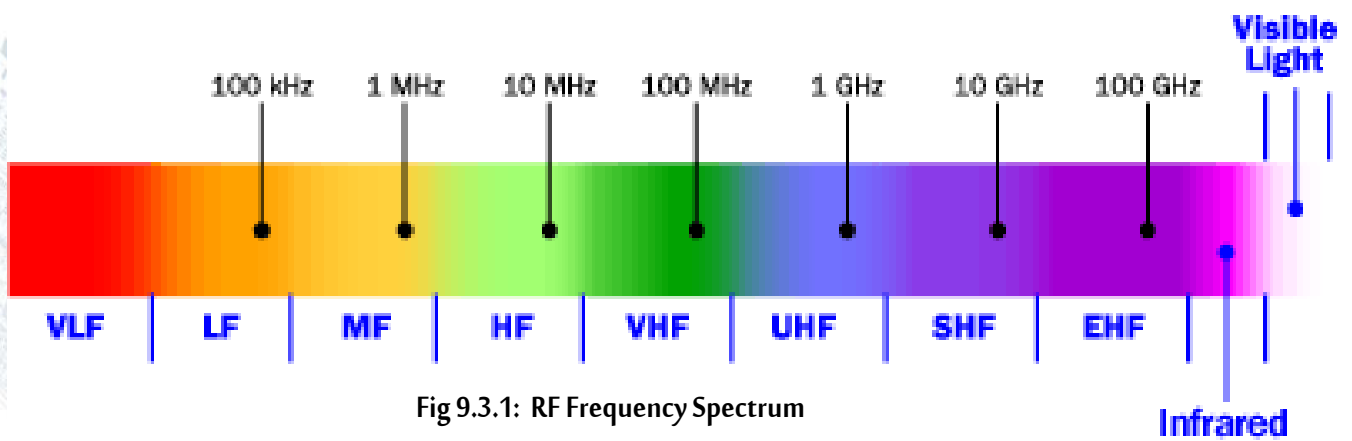

Fig 9.3.1: RF Frequency Spectrum

9.4 RF MODULE INTERFACING WITH PIC

The term wireless is very much hyped! Whenever we hear the term wireless, stuffs like Mobile telecommunication (GSM), Wi-Fi, Bluetooth, RF Communication, Wireless networks, Zigbee, I2C, SPI, DTMF, 802.11b, SimplicTI etc etc etc. Well, fortunately or unfortunately, all of these protocols can be interfaced with a microcontroller in one way or the other. But what matters is, The level of complexity.

To start off, RF (Radio Frequency) Communication is the most preferred and low cost solution. All we need is a RF Module (Transmitter-Receiver Pair). Now, that's not all. RF Communication works on the principle of Serial Communication. Thus, We need something which converts the conventional n-bit (4-bit, 8-bit, 16-bit, etc) data into serial data. For this, we have two choices:

- Use a microcontroller to convert the n-bit data into serial data and vice-versa
- Use serial encoders/decoders to do the same.

But, If We Use the Both Then It Would Be More Innovative & Impressive As We'll Be Able To Get The Output On L.C.D As Well. For L.C.D Interfacing With Encoder/Decode & Serial Ports We Strongly Need a Microcontroller, Which In Our Project is PIC 16F73. So Here's The Working Below:

9.5 RF COMMUNICATION BLOCK DIAGRAM

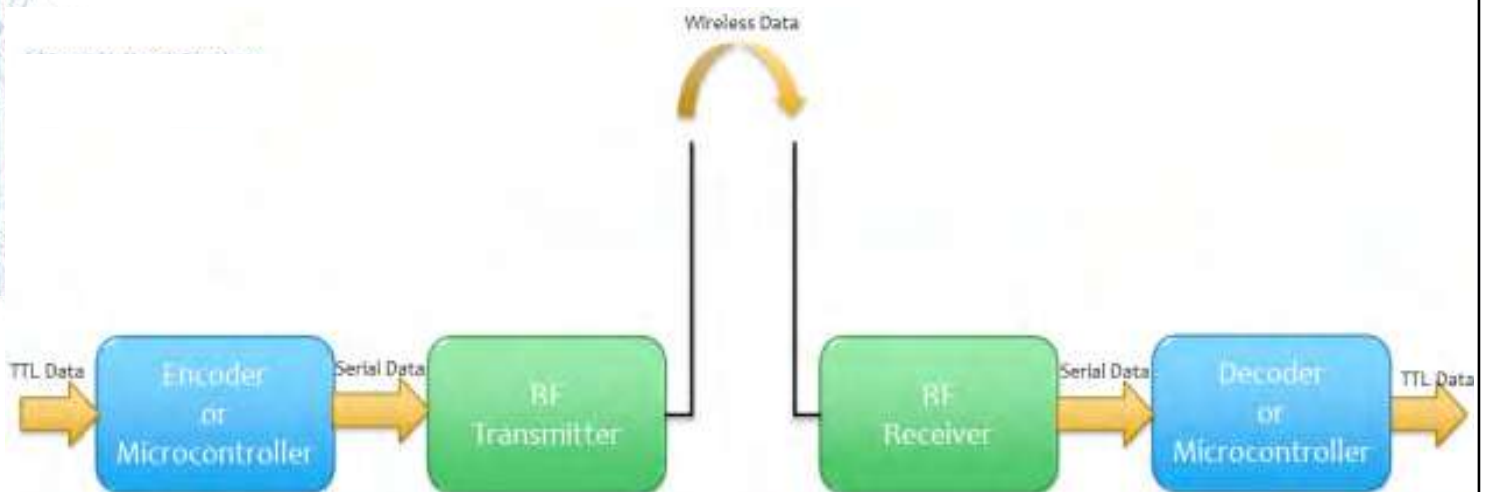

Fig: 9.5 Block Diagram Of RF Operation

A general RF communication block diagram is shown above. Since most of the encoders/decoders/microcontrollers are TTL compatible, most of the inputs by the user will be given in TTL logic level. Thus, this TTL input is to be converted into serial data input using an encoder or a microcontroller. This serial data can be directly read using the RF Transmitter, which then performs ASK (in some cases FSK) modulation on it and transmit the data through the antenna.

In the receiver side, the RF Receiver receives the modulated signal through the antenna, performs all kinds of processing, filtering, demodulation, etc and gives out a serial data. This serial data is then converted to a TTL level logic data, which is the same data that the user has input.

RF Modules are used wireless transfer data. This makes them most suitable for remote control applications, as in where we need to control some machines or robots without getting in touch with them (may be due to various reasons like safety, etc). Now depending upon the type of application, the RF module is chosen. For short range wireless control applications, an ASK RF Transmitter-Receiver Module of frequency 315 MHz or 433 MHz is most suitable.

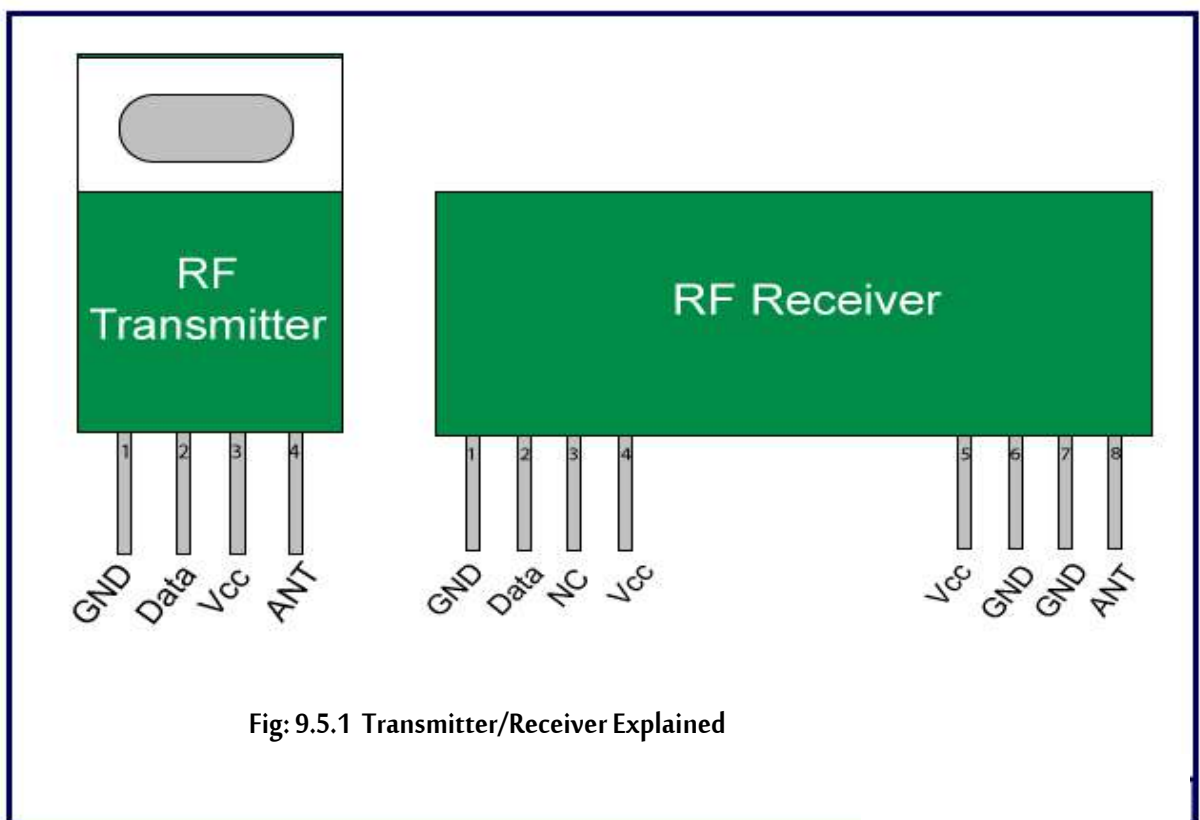

Fig: 9.5.1 Transmitter/Receiver Explained

RF Transmitter

Pin No.	Name	Function
1	GND	Ground (0V)
2	DATA	Serial Data Input
3	Vcc	Supply Voltage (5V)
4	ANT	Antenna Output

RF Receiver

Pin No.	Name	Function
1	GND	Ground (0V)
2	DATA	Serial Data Output
3	NC	No Connection
4	Vcc	Supply Voltage (5V)
5	Vcc	Supply Voltage (5V)
6	GND	Ground (0V)
7	GND	Ground (0V)
8	ANT	Antenna Input

FEATURES

- Range in open space(Standard Conditions) : 100 Meters
- RX Receiver Frequency : 433 MHz
- RX Typical Sensitivity : 105 Dbm
- RX Supply Current : 3.5 mA
- RX IF Frequency : 1MHz
- Low Power Consumption
- Easy For Application
- RX Operating Voltage : 5V
- TX Frequency Range : 433.92 MHz
- TX Supply Voltage : 3V ~ 6V
- TX Out Put Power : 4 ~ 12 Dbm

This has single channel for data transfer, thus serial data communication is used.

ANTENNA

Now that all the connections are made, we must choose an antenna for signal transmission. Usually, a 20-30 cm wire serves best. It is sufficient to give a range of 80 meters in open region. To improve the efficiency, we can also use a coiled wire (take a wire and make it into a coil). It increases the signal strength.

9.6 SOURCE CODE FOR PIC

Since, As We Know The PIC 16F73 is a Micro-Controller Which Without a Programming Code is As Dumb As a Small Plastic Stuff With Having Some Sharp Pins. So, To Make This PIC Our Project's CPU We've Added The Following Programming Written In Embedded C Using MikroC As a Compiler.

```
Void main()
{
    TRISC=0X0f; PORTB=0;           // PORTC is Considered As Input & PORTB As Output.

    LCD_Init(&PORTB);             // Initilize The LCD Connected On PORTB.
    LCD_Cmd(LCD_CLEAR);           // Clear display.
    LCD_Cmd(LCD_CURSOR_OFF);     // Turn cursor off.
    LCD_Out(1,1,"Device 1 is ");
    LCD_Out(2,1,"Device 2 is ");
    LCD_Out(2,9,"OFF");
    LCD_Out(1,9,"OFF");

    while(1)                       // An Infinite Loop.
    {

        if(PORTC.F0==0)
        {
            LCD_Out(2,9,"OFF");
            LCD_Out(1,9,"OFF");
            PORTC.F6=0;             // The Decision Oriented Pin Of PORTC.
            PORTC.F7=0;           // The Decision Oriented Pin Of PORTC.
        }

        if(PORTC.F1==0)
        {
            LCD_Out(2,9,"OFF");
            LCD_Out(1,9,"ON");
            PORTC.F6=1;
            PORTC.F7=0;
        }

        if(PORTC.F2==0)
        {
            LCD_Out(2,9,"ON");
            LCD_Out(1,9,"OFF");
            PORTC.F6=0;
            PORTC.F7=1;
        }

        if(PORTC.F3==0)
        {
            LCD_Out(2,9,"ON");
            LCD_Out(1,9,"ON");
            PORTC.F6=1;
            PORTC.F7=1;
        }
    }
}
```

9.7 SERIAL ENCODER/DECODER

The most popular serial encoder/decoder used is the HT12D-HT12E pair. The HT12E Encoder ICs are series of CMOS LSIs for Remote Control system applications. They are capable of Encoding 12 bit of information which consists of N address bits and 12-N data bits. Each address/data input is externally trinary programmable if bonded out.

8-Address
4-Address/Data

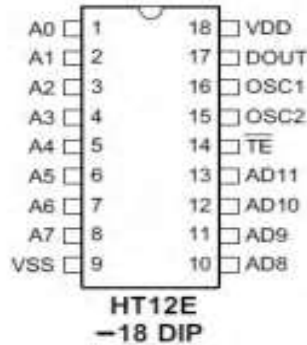

FEATURES - ENCODER

- 18 PIN DIP
- Operating Voltage : 2.4V ~ 12V
- Low Power and High Noise Immunity
- CMOS Technology
- Low Standby Current and Minimum Transmission Word
- Built-in Oscillator needs only 5% Resistor
- Easy Interface with and RF or an Infrared transmission medium
- Minimal External Components

The HT12D Decoder ICs are series of CMOS LSIs for remote control system applications. This ICs are paired with each other. For proper operation a pair of encoder/decoder with the same number of address and data format should be selected. The Decoder receive the serial address and data from its corresponding decoder, transmitted by a carrier using an RF transmission medium and gives output to the output pins after processing the data.

8-Address
4-Data

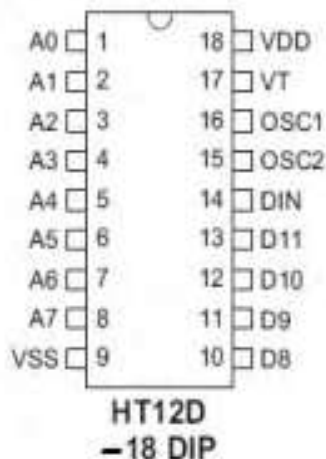

FEATURES - DECODER

- 18 PIN DIP
- Operating Voltage : 2.4V ~ 12.0V
- Low Power and High Noise Immunity
- CMOS Technology
- Low Stand by Current
- Ternary address setting
- Capable of Decoding 12 bits of Information
- 8 ~ 12 Address Pins and 0 ~ 4 Data Pins
- Received Data are checked 2 times, Built in Oscillator needs only 5% resistor
- VT goes high during a valid transmission
- Easy Interface with an RF of IR transmission medium
- Minimal External Components

APPLICATIONS

- Burglar Alarm, Smoke Alarm, Fire Alarm, Car Alarm, Security System
- Garage Door and Car Door Controllers
- Cordless telephone
- Other Remote Control System Compatibility
- Compatible with RF Modules 433 MHz Link RF Modules (Tx + Rx Pair) 433Mhz

TROUBLESHOOTING

It's obvious that we won't get the result in the first go itself! It's completely normal, even in any case! . In that case, just try out the simple wired communication. Connect the DOUT of the encoder directly to the DIN of the decoder using a wire. Then check and recheck your connections, check whether the address is the same, whether you have missed any Vcc or GND connection, etc. If still then a successful link is not established, change the encoder/decoder ICs. Once the link is established, connect the RF module and do the same. Try adjusting the antenna position, touch the antenna (touching the antenna will make yourself an antenna!), etc.

9.8 How Do RF Transmitters And Receivers Work?

An **RF transmitter** generates radio frequency waves in its circuits, and to this 'carrier signal', it adds the information part by modulating the carrier signal. This composite signal (carrier plus information) is then fed to an antenna (aerial).

The aerial induces a corresponding signal into the atmosphere, by altering the Electric and Magnetic fields at (obviously) the same frequency. The impedance of 'free space' is few tens of Ohms to a few hundreds of Ohms.

[Impedance may be considered analogous to resistance, but with reactive properties as well.] The power emitted by the transmitter can vary from a megawatt or so (for VLF signals) to a few watts for handheld devices.

An **Rf receiver** receives the signal from the atmosphere, from its own aerial. The receiver aerial is often quite simple, and the signal level is typically of a few microvolts. This it tunes in (gets rid of unwanted signals and amplifies only the wanted ones).

The receiver circuits then strip the information part of the signal from the carrier part, and amplify this to a useful level for audio or video.

The actual signal into the loudspeaker will be a few tens of volts. In spite of the inefficiency of loudspeakers, (often only a few %) the signal eventually appears at a level that may be heard. A background radio will be a few milliwatts of power. Even a very loud sound is only a few watts of radiated (sound) energy!!



Fig:9.8 RF Module

9.9 CIRCUIT IMPLEMENTATION

9.9.1 TRANSMITTER SECTION

Make the following circuit on an etched PCB. Here, we have used four switches S1, S2, S3 and S4 to give 4-bit parallel data (D0-D3). Since the switches are in active low state (i.e. low signal is sent when the switch is pressed), we need to add external pull-up resistors as shown, so as to provide a high signal by default. A resistance as high as 1M ohm is required in between OSC1 and OSC2 pins. The Transmitter Enable (TE, pin 14) pin is an active low pin. Thus, it is permanently grounded, so as to enable the transistor always. The output serial data DOUT is fed to the RF Transmitter Module directly.

The most important thing lies in the address pins (A0-A7, pin1-8). Suppose we have two wireless devices (A and B) in our house, both have different remote controls (AA and BB) and both implement the same type of RF module (say 433 MHz). AA is the remote control of A and BB is of B. Now, we obviously wouldn't want AA to control B (which is the most probable case since both the devices use same kind of RF module, having same frequency!). This is where address pins come into play. There are 8 address pins, thus giving us an opportunity to have 8! (8 factorial) different and independent ways to connect to a device, so that there is no interference. The address pins MUST have the same address in both transmitter and receiver, or else the data won't be transferred. Refer to the receiver circuit for more details.

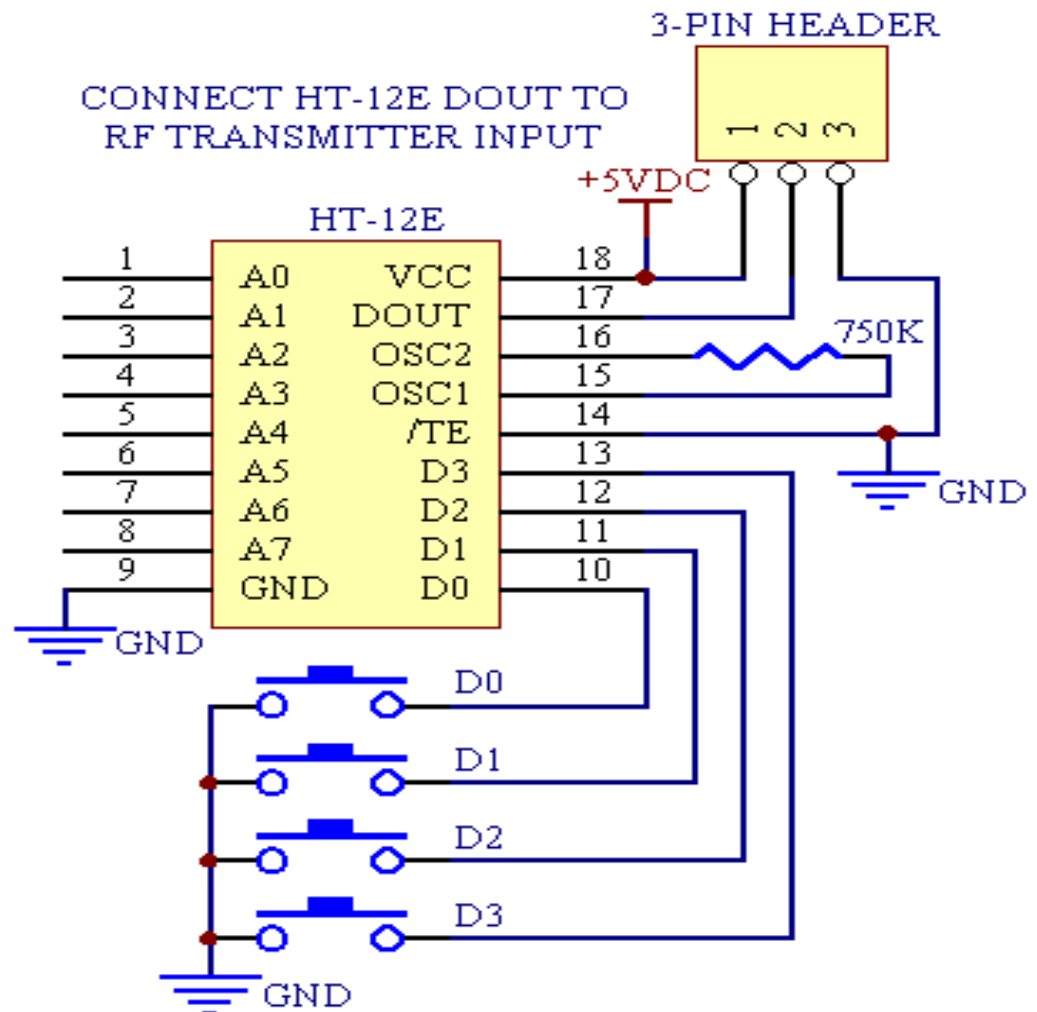

Fig: 9.9.1 Operation Of Serial Encoder

9.9.2 RECEIVER SECTION

The circuit of the receiver is also quite simple. Capacitor C1 is used between Vcc and GND for noise filtering. Apart from that, all the address pins (A0-A7, pin 1-8) are grounded, just as in transmitter. This is to ensure that the transmitted data is being received. Both the transmitter and the receiver MUST have the same address pins configuration. Pin 17 (VT) is enabled whenever the receiver receives any data. The serial data received by the RF Receiver module is directly fed to pin 14 (DIN), which is then converted into 4-bit parallel data (D0-D3). A 33k ohm resistor is connected in between OSC1 and OSC2.

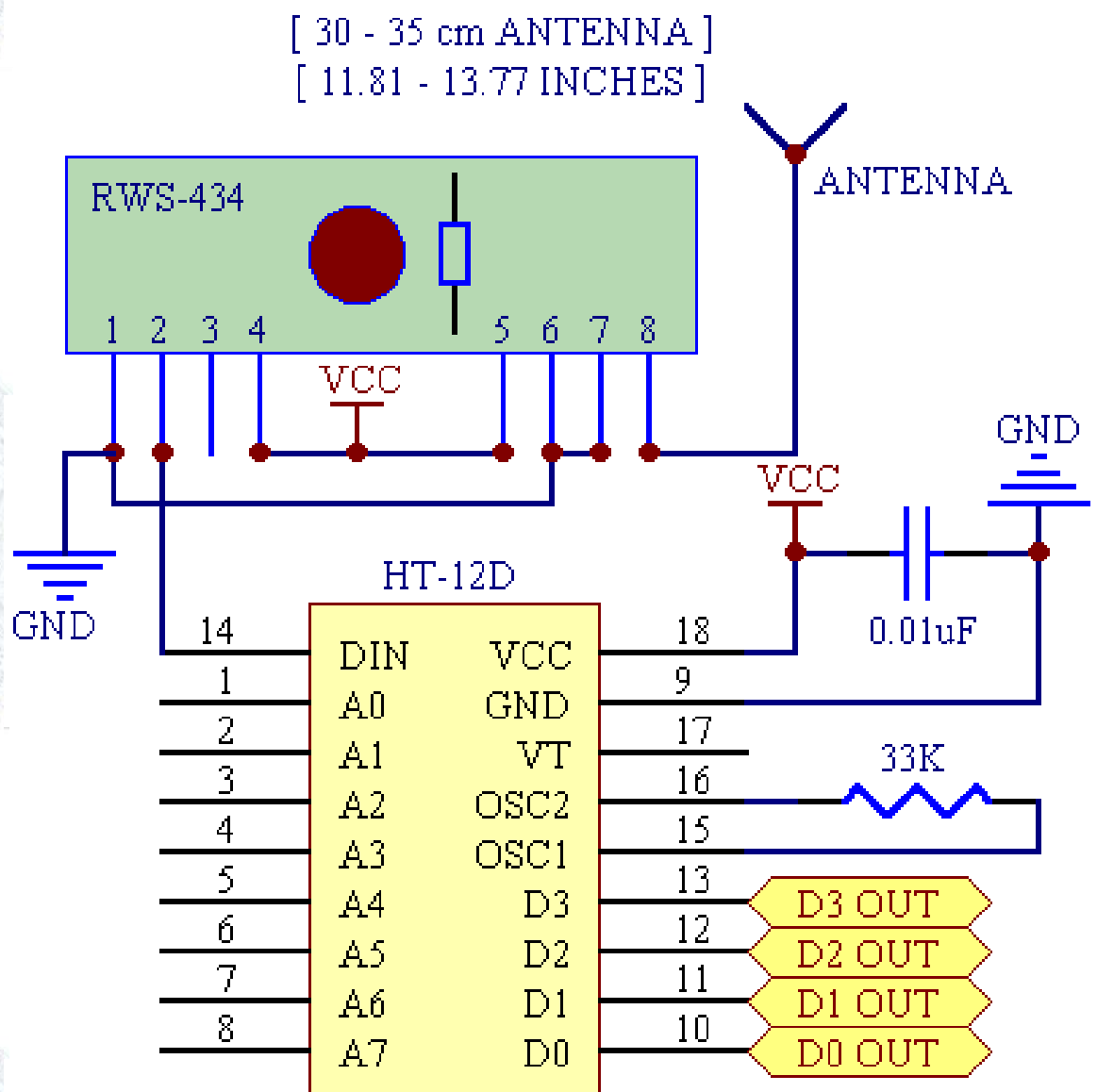

Fig: 9.9.2 Operation Of Serial Decoder

9.10 OPERATIONAL FUNCTION OF TRANSMITTER & RECEIVER THROUGH FLOWCHART

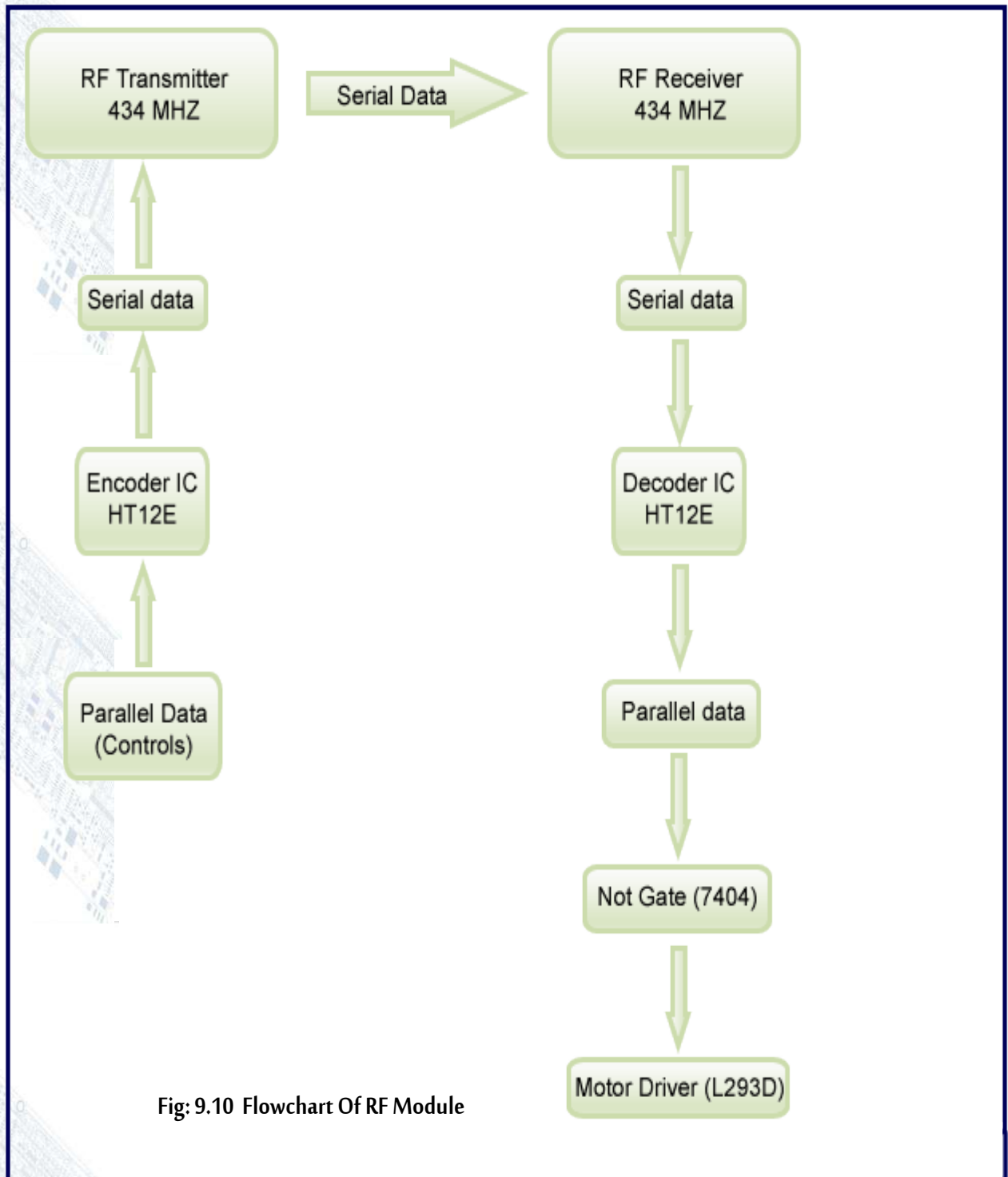

Fig: 9.10 Flowchart Of RF Module

10. WHAT IS HEX FILE FORMAT AND HOW'S IT WORK?

WHEN WE CREATE A PROGRAM & BUILD IT (OR RUN IT), THE COMPILER CREATES A FILE WITH HAVING AN EXTENSION ".hex". THIS .hex EXTENSION PLAYS VERY IMPORTANT ROLE WHILE BURNING THE PROGRAM & ALSO IT PROVIDES AN APPROPRIATE HELP FOR USER TO INTERFACE THE MICRO-CONTROLLER WITH SERIAL PORTS & LET IT TO WORK.



RFModule.c



RFModule.hex

The Intel hex (ihex) generally known as hex file, is a format used to store machine language code in hexadecimal form. It is widely used format to store programs to be transferred to microcontrollers, ROM and EEPROM. The compilers convert the programs written in assembly, C etc into corresponding hex files, which are dumped into the controllers using burners/programmers.

The microcontroller understands machine language consisting of zeroes and ones. It's difficult rather practically impossible for humans to write codes in zeros and ones. Hence we use some high level languages like C, C++, Java, etc. And later a compiler is used to convert these codes into machine language which are stored in a hex file format. A hex file is a text file with the extension .hex.

```
:10000000C942A000C9434000C9434000C943400AA
:10001000C9434000C9434000C9434000C94340090
```

10.1 STRUCTURE OF .hex FILE

1. Every line in a hex file always starts from colon (:)
2. The first two digits CC (Character Count) represent the total number of data byte in that line. Here in this example, 10 (hexadecimal) are the first two digits which mean that there is 16 byte (in decimal) of data in the line.
3. The next four digits represent the starting address of the memory where the data stored in the line needs to be dumped. 4. After address the next two digits represent whether this is the last line of code or not. TT=0, means the code is not complete and there are more lines after this line and TT=1 means this is the last line of the code.
5. XXXX.....XX are the data bytes which have to be dumped into the memory. The number of data bytes in a particular line is equal to the number indicated by character count digits (CC).
6. SS is the checksum byte of that line.

The hex file is a text file so one can easily change contents of a hex file. The corrupted line can be identified using the check sum) (SS) byte.

1 1 . APPLICATIONS OF WIRELESS RF MODULE

The very first thing that concern to any engineering student before choosing the project is it's Applications. That means How much innovative the project is ? And How We can make it more innovative & also make it up-to-date so that it can extend to the bigger Applications of this age of Smart & Vast life. And, Also It's Applications must be cost effective so that everyone can use it without any economical hesitation.

The Application Of Any Project is Considered as The Future Insight Of That Project.

THE VERY BEST APPLICATION OF RADIO FREQUENCY IS RFID

1 1 . 1

RADIO-FREQUENCY IDENTIFICATION (RFID) is the use of a wireless non-contact system that uses radio-frequency electromagnetic fields to transfer data from a tag attached to an object, for the purposes of automatic identification and tracking. Some tags require no battery and are powered by the electromagnetic fields used to read them. Others use a local power source and emit radio waves (electromagnetic radiation at radio frequencies). The tag contains electronically stored information which can be read from up to several meters (yards) away. Unlike a bar code, the tag does not need to be within line of sight of the reader and may be embedded in the tracked object.

RFID tags are used in many industries. An RFID tag attached to an automobile during production can be used to track its progress through the assembly line. Pharmaceuticals can be tracked through warehouses. Livestock and pets may have tags injected, allowing positive identification of the animal. RFID identity cards can give employees access to locked areas of a building, and RF transponders mounted in automobiles can be used to bill motorists for access to toll roads or parking. Since RFID tags can be attached to clothing, possessions, or even implanted within people, the possibility of reading personally-linked information without consent has raised privacy concerns.

1 1 . 1 . 1 OPERATION OF RFID

A radio-frequency identification system uses tags, or labels attached to the objects to be identified. Two-way radio transmitter-receivers called interrogators or readers send a signal to the tag and read its response. The readers generally transmit their observations to a computer system running RFID software or RFID middle ware. The tag's information is stored electronically in a non-volatile memory. The RFID tag includes a small RF transmitter and receiver. An RFID reader transmits an encoded radio signal to interrogate the tag.

The tag receives the message and responds with its identification information. This may be only a unique tag serial number, or may be product-related information such as a stock number, lot or batch number, production date, or other specific information. Tags may either be read-only, having a factory-assigned serial number that is used as a key into a database, or may be read/write, where object-specific data can be written into the tag by the system user. Field programmable tags may be write-once, read-multiple; "blank" tags may be written with an electronic product code by the user.

RFID tags contain at least two parts: an integrated circuit for storing and processing information, modulating and demodulating a radio-frequency (RF) signal, collecting DC power from the incident reader signal, and other specialized functions; and an antenna for receiving and transmitting the signal.

Fixed readers are set up to create a specific interrogation zone which can be tightly controlled. This allows a highly defined reading area for when tags go in and out of the interrogation zone. Mobile readers may be hand-held or mounted on carts or vehicles.

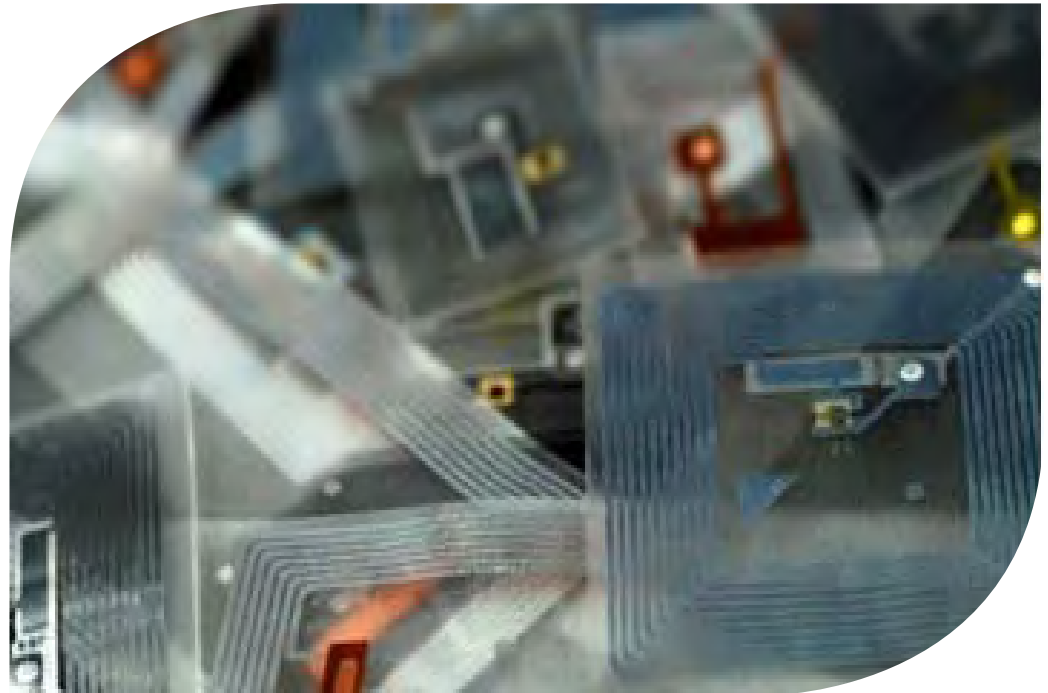

Fig: 11.1.1 RFID

11.1.2 APPLICATIONS OF RFID

The RFID tag can be affixed to an object and used to track and manage inventory, assets, people, etc. For example, it can be affixed to cars, computer equipment, books, mobile phones, etc. In social media, RFID is being used to tie the physical world with the virtual world. RFID in Social Media first came to light in 2010 with Facebook's annual conference.

RFID offers advantages over manual systems or use of bar codes. The tag can be read if passed near a reader, even if it is covered by the object or not visible. The tag can be read inside a case, carton, box or other container, and unlike bar codes, RFID tags can be read hundreds at a time. Bar codes can only be read one at a time. RFID can be used in a variety of applications, such as:

- Access management
- Tracking of goods
- Tracking of persons and animals
- Toll collection and contactless payment
- Machine readable travel documents
- Smartdust (for massively distributed sensor networks)
- Tracking sports memorabilia to verify authenticity
- Airport baggage tracking logistics

1 1.2 WIRELESS MOUSE TECHNOLOGY

The mouse is an extremely popular device. While the majority of mice are connected directly to the computer's peripheral input via a cord and the computer's main power powers it, wireless mice are becoming extremely popular as they give computer users cordless accessibility to their mice and their computer.

Wireless mice usually work via radio frequencies commonly referred to as RF. RF wireless mice require two components to work properly – a radio transmitter and a radio receiver.

1 1.2.1 RF TRANSMITTER

A radio frequency (RF) transmitter is usually integrated inside the mouse. The mouse records its movements and buttons that are clicked and then sends this information via radio signals to the receiver.

1 1.2.2 RF RECEIVER

The radio frequency (RF) receiver usually connects to the computer's peripheral mouse input. It receives these RF signals, decodes them, and then sends these signals directly to the computer as normal. RF receivers usually come in a few styles. The majority come as built-in components that connect to the mouse input, others come as a separate card that is installed in one of the many expansion slots of computers, and the third type of receiver is a separate unit that is connected to a cable going directly to the computer's peripheral input. Since the technology has been mastered, most wireless mice have integrated receivers that plug into a computer's peripheral input and are very small in size.

1 1.2.3 RF FREQUENCIES

Wireless mice mainly use Radio frequencies to transmit data from the mouse to the computer. The most common type of RF is the 802.11b or 802.11g. These frequencies operate at 2.4 gigahertz and at these frequencies a mouse can transfer data at very quick speeds, either 11 Mbps or 56 Mbps. 2.4 gigahertz frequencies. These frequencies are very stable and usually have little or no interference in a work or home environment. They also have a decent range of about 100 to 150 feet which is more than enough for mouse operation.

11.2.4 *ADVANTAGES OF WIRELESS MICE*

RF wireless mice are a great technology because of their overall reliability and stability. Other forms of communication such as Infrared technology need to be in “line of sight” in order to work properly, which makes using them with a mouse impractical.

Some of the reasons that RF technology is great for wireless mice includes the fact that the RF transmitter housed in the mouse requires low power. Usually, RF wireless mice are powered by small, light weight batteries that are either disposable or usually rechargeable with an included recharging dock.



Fig: 11.2.4 Wireless RF Based Mouse

11.3 *INDUSTRIAL AUTOMATION*

In Industrial automation there is an ever-increasing need to monitor and analyse the status or wear and tear of machines and sensors. Using the low power wireless connectivity of the RF Module is a low cost high Reliability method of getting access to this data. A series of mRF prototypes consisting of a contact mechanism and actuator with return spring were fabricated assembled, inspected, and characterized for electromechanical performance. Characterization results led to specific conclusions regarding capabilities of the mRF product, and the integrated manufacturing technique.

The performance objectives of low RF loss, high electrical isolation, and device compactness drive the fabrication requirements for modern RF relays. and contact resistance for consistent electrical response.

Like: **Stationary Transmitter Systems etc.**

1.1.4 CUSTOM WIRELESS REMOTE CONTROLS

The applications for simple RF wireless switching are limitless. Nearly any device that can be electrically turned on or off can be controlled remotely using Remote Control Technology's wireless switching technology. From tactical airfield lighting to automating pump operations, Remote Control Technology's goal is to provide a Simple Wireless Solution that is easy to install and operate. The following are a few examples companies with custom built systems:

1.1.4.1 WIRELESS X-RAY SYSTEMS



THE NEED: L3 needed to integrate a wireless perimeter detection system into their CX-2500M mobile X-ray screening system using Southwest Microwaves M.I.L. PAC 385 system. The unit needed to operate at a EU compliant radio frequency and have multiple safety backups.

THE SOLUTION: Remote Control Technology modified several wireless switch systems to have an increased rate of transmission. This way, a barrier penetration or a twelve second failure to transmit (potential vandalism or system error) would be detected. In addition, a custom handheld transmitter and keypad were designed to allow operators a means to enable and disable the system.

1.1.4.2 LONG-RANGE WIRELESS SWITCH SYSTEM (HAND-HELD)



The Long Rang Wireless Switch System Hand Held (LRWSSHH) is designed for long range and simple wireless switching. Applications where faulty wire replacement or new installation is not possible or practical, the LRWSSHH is the simple solution for:

- Pump Control
- Valve Actuation
- Conveyor Control
- Center Pivots
- Light Control
- Alarm Systems
- PLC Activation
- Engine Control
- Wireless Automation

11.5 MACHINE TO MACHINE (M2M) RF WIRELESS NETWORKING

Machine-to-machine (M2M) refers to the technologies that allow both wireless and wired systems to communicate with other devices of the same ability. M2M uses a device (such as a sensor or meter) to capture an event (such as temperature, inventory level, etc.), which is relayed through a network (wireless, wired or hybrid) to an application (software program), that translates the captured event into meaningful information (for example, items need to be restocked). Such communication was originally accomplished by having a remote network of machines relay information back to a central hub for analysis, which would then be rerouted into a system like a personal computer.

However, modern M2M communication has expanded beyond a one-to-one connection and changed into a system of networks that transmits data to personal appliances. The expansion of wireless networks across the world has made it far easier for M2M communication to take place and has lessened the amount of power and time necessary for information to be communicated between machines. These networks also allow an array of new business opportunities and connections between consumers and producers in terms of the products being sold.

Machine to Machine wireless communication has many applications, from cost recovery solutions to equipment monitoring and environmental observation.



Fig: 11.5 M2M PICTail™ Daughter Board

1.6 ROBOT CONTROL USING RF MODULE

A Robot is a mechanism that can move automatically. A system designed to record and report on discrete activities within a process is called as Tracking System. In the same procedure user can develop a methodology of robot direction system for robotics to control and achieve accurate direction for a class of non-linear systems in the presence of disturbances and parameter variations by using wireless communication technique.

The simple system created using RF module track the robot by using wireless communication i.e. from Control section (acts as transmitter) An ejecting the control signals, then the robot receives (acts as receiver) the signals, according to the signals it will change the direction in different paths like forward, backward, left, right.

Simple robot is easy to set up, And support the required hardware as desired and also serves as the needs in future.

SPECIFICATIONS:

1. Micro controller
2. Dc gear motors
3. Relays
4. Uln2003
5. Rf modules
6. Power supply



RF CONTROLLED ROBOT:

TRANSMITTER SECTION:

Key pad

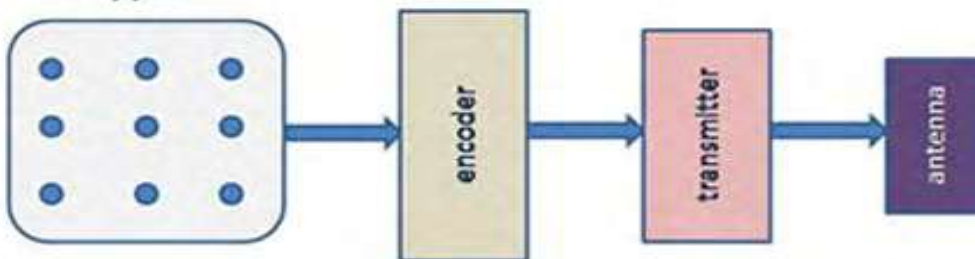

RECEIVER SECTION:

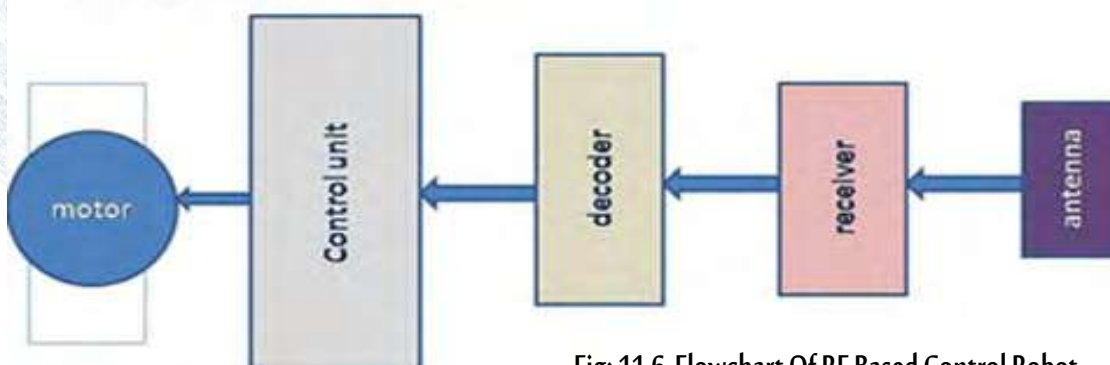
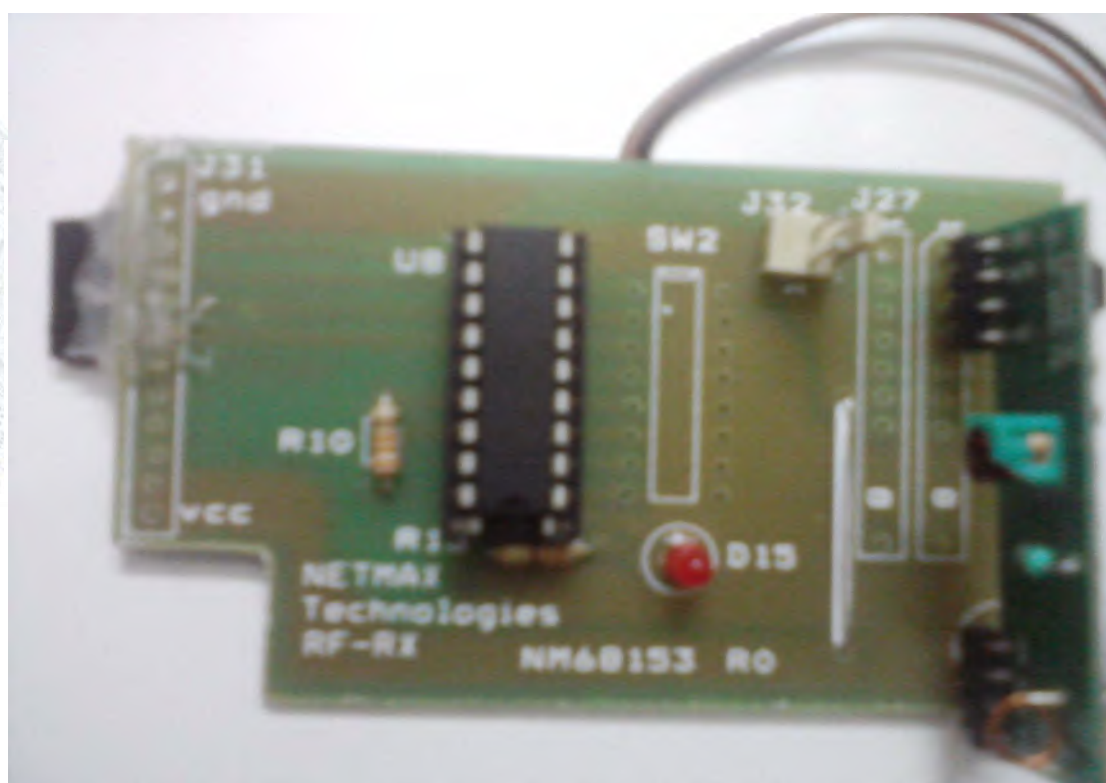
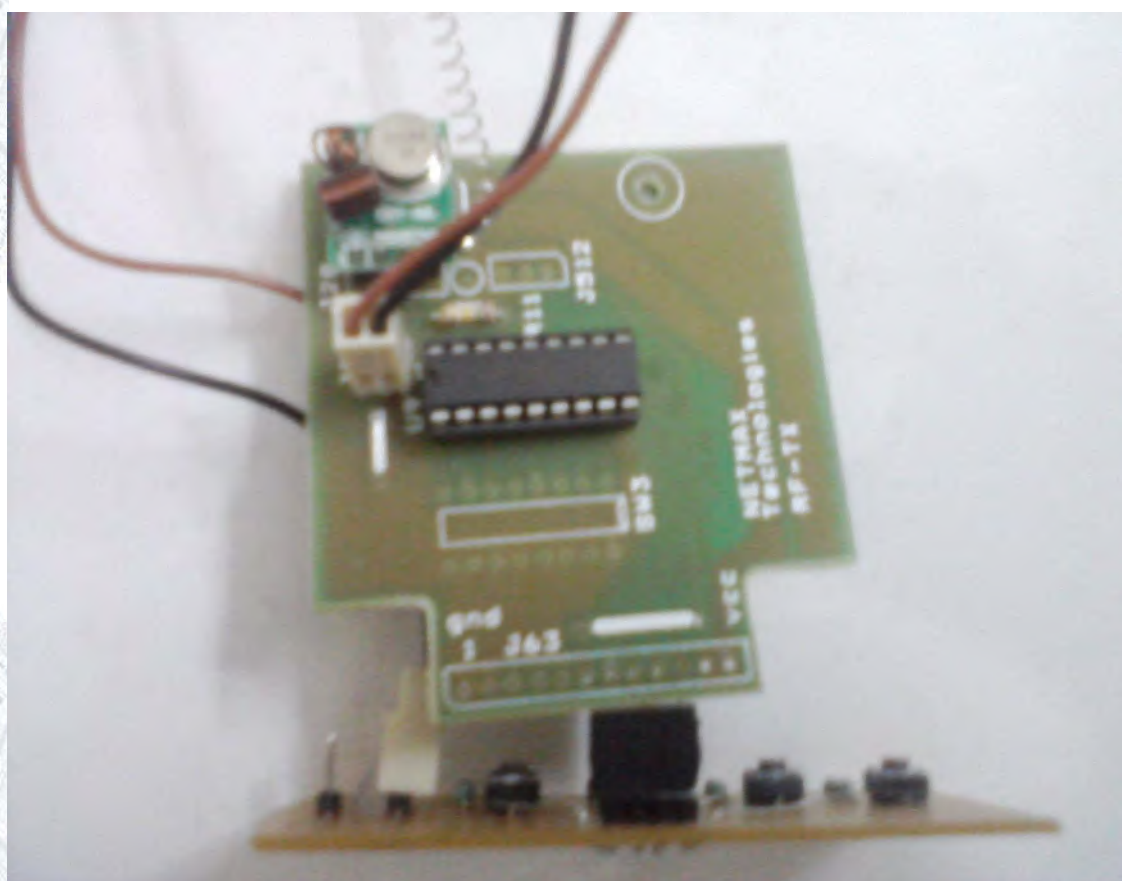

Fig: 11.6 Flowchart Of RF Based Control Robot

12. ACTUAL PCB PHOTOGRAPHS



Receiver End Of Project (RF-RX)



Transmitter End Of Project (RF-TX)



Sending The Signal From Transmitter



Receiver Installed On PIC Based PCB With Transformer & Relay Connected



Additional Output Showing On Installed LCD

13. Future OF PROJECT

AS, WE KNOW THE SECOND THING AFTER THE APPLICATIONS OF ANY PROJECT WHICH CONCERNS THE MOST TO ANY ELECTRONICS STUDENT IS THE FUTURE OF THAT PROJECT BY ANY MEANS, OFF COURSE. SO, HERE IN FOLLOWING CHAPTER I'M GOING TO ADD SOME OF THE POSSIBLE FUTURISTIC INSIGHTS OF WIRELESS RF MODULE. AND, WELL TRY NOT TO BE 'RAY KURZWEIL' & 'STEPHEN HAWKING', THIS FUTURISTIC INSIGHT MAY NOT BE VERY IMPRESSIVE & INNOVATIVE BUT THIS WOULD DEFINATELY BE THE BEST POSSIBLE INSIGHTS ABOUT THE PROJECT.

13.1

IDENTIFYING OBJECTS USING RF TRANSMITTERS AND RECEIVERS AND RETRIEVING DATA USING GSM

Abstract—

To provide a system for monitoring and locating objects using Radio Frequency (RF) transmitters and receivers, and querying about the objects using mobile phones. An object represents a real world entity. This system is based on RF transmitters that are tagged to the objects of everyday use and have the capability of transmitting signals and a receiver that detects the transmission of the tagged object and stores its corresponding location in the database which is created specifically for information maintenance of the tagged objects. Mobile phones are used to query the location of the tagged object by sending a message to the Subscriber Identity Module (SIM) connected to a Global System for Mobile Communications (GSM) modem. This GSM modem fetches the location and other relevant information from the database and Encapsulates this information into a message which is sent back to the mobile phone that has requested the information.

13.2 RADIO TRANSMITTER DESIGN

Abstract—

Radio transmitter design is a complex topic which can be broken down into a series of smaller topics. A radio communication system requires two tuned circuits each at the transmitter and receiver, all four tuned to the same frequency. The transmitter is an electronic device which, usually with the aid of an antenna, propagates an electromagnetic signal such as radio, television, or other telecommunications.

- The transmitting system consists of two tuned circuits such that the one containing the spark-gap is a persistent Oscillator; the other, containing the aerial structure, is a free radiator maintained in oscillation by being coupled to the first (Nikola Tesla and Guglielmo Marconi).
- The oscillating system, including the aerial structure with its' associated inductance-coils and condensers, is designed to be both a sufficiently persistent oscillator and a Sufficiently active radiator (Oliver Lodge).

13.3 TWO CHANNELS RF REMOTE CONTROL

Abstract—

How many times have we need some remote control to handle some electric device ? Many times, off course. There are lot of remote controls like infrared, RF, SMS and more. The basic small-range remote controls are 2, Infrared and RF (Radio Frequency). One of the weaks of Infrared is that the signal can not pass the walls. So, if we want to control our garage door, the only way is to use some RF remote control. The circuit (transmitter and receiver) uses few components and ordinary. It's easy to be built because we don't have to tune-up any coil or variable capacitor. The RF modules are fix to work in 418MHz area.

Any RF Based Remote Control Having Following Categories Can Be Designed For It's Future Uses With Some Advance Knowledge:

- a.) The verification of the received data because many other devices are working in this frequency (418MHz)
- b.) And the power-saving of the transmitter. A transmitter must have long battery life. It's not the best choice for a user to change the battery every 3 days.
- c.) The receiver's power supply should be of long life, because receiver must be working all the time.

The Following Components could be used:

The power supply of the RF receiver is constituted by 2 voltage regulator, LM7812 and LM7805. The first one (12V) is only for powering the 2 relays and the 2nd (5V) for powering the AVR microcontroller and the RF receiver module. The LED, is a voltage indicator and the 4 capacitors should be for flattening the voltage.

13.4 WEATHER MONITORING SYSTEM

Abstract—

Well, this might be considered as a complex project to work with RF, But RF Module system could be used best with Weather Monitoring System. In Weather Monitoring System we're supposed to put a transmitter with having some kind of sensors (like Temp. Sensors, Heat sensors, Rain sensors etc.) Installed on it placed at any open place or on the roof of house. That transmitter would send current updates of weather to the receiver which is placed at the ground floor of the house using RF Communication. And, this RF system becomes the live updation system for a comman house hold families. Also, we can add some kind of Warning buzzer or LCD display messages for weather notifications. This definately could be considered as one of the most innovative project with RF Module.

14. APPENDIX

ABSTRACTION allows us to layer semantics of complex system, breaking them into more manageable pieces.

RADIO FREQUENCY : Radio Frequency (RF) is a rate of oscillation in the range of about 3 kHz to 300 GHz

DEVICE : An instrumentality invented for a particular purpose

WIRELESS : Wireless is a term used to describe telecommunications in which Electromagnetic waves carry the signal over part or all of the communication path.

MODULE : A self-contained component (unit or item) that is used in combination with other components

LED : Light Emitting Diode

LCD : Liquid Crystal Display

USB : Universal Serial Bus; a way of attaching peripheral devices to a computer

OrCAD : Oregon + CAD, OrCAD is a proprietary software tool suite used primarily for electronics design automation

PCB : Printed circuit board (PCB) provides both the physical structure for mounting and holding the components as well as the electrical interconnection between the components.

CAPTURE CIS : Component information system (CIS), A Part Of OrCAD Suite Used For Ckt Designing.

MIKRO C : MikroC is a powerful, feature rich development tool (Compiler) for PICmicros.

BOOTLOADER : The bootloader receives a user program from the PC and writes it in the flash memory, then launches this program in execution.

NET-LIST : Net-list file is a document file which contains information about the logical Interconnections between signals and pins.

LAYOUT PLUS : Layout plus is one part for the PCB design in which we place as well as route the components an set unit of measurement, grids, and spacing in OrCad.

PIC BURNER : PIC Burner is very versatile software. We can use different kinds of hardware with it, because the pins used on parallel port can be set using a simple ini-file.

PIC : Peripheral Interface Controller, A Micro-Controller

USART : Universal Synchronous Asynchronous Reciever & Transmitter

RFID : Radio Frequency Identification

COMMUNICATION : The activity of communicating; the activity of conveying information

AUTOMATION : The act of implementing the control of equipment with advanced technology; usually involving electronic hardware

TRANSMITTER : Any Device Set used to broadcast radio or tv signals

RECEIVER : Any Device Set that receives radio or tv signals

15. BIBLIOGRAPHY

BOOKS:

PIC Microcontroller Notes - NetMax Technologies.

Data Sheet- PIC16F73 - Microchip Co. LTD.

*Data Sheet - HT12E/2¹² Encoder
- HT12D/2¹² Decoder* } → *Holtek Co. LTD.*

Data Sheet - ULN 280 - Texas Instruments CO. LTD.

WEB LINKS:

<http://www.wikipedia.org/>

<http://www.alldatasheet.com/>

<http://www.microchip.com/>

<http://www.remotecontroltech.com/>

<http://www.rentron.com/>

<http://howstuffworks.com/>

<http://Mikroelektronika.com/>



PERSONAL NOTES



WELL, GUYS PLEASE DON'T CONSIDER THIS PAGE AS AN ANOTHER BORING CHAPTER OF THIS REPORT OF RF PROJECT. I'M ABHI SHARMA, THE PERSON WHO CREATED THAT PROJECT & IT'S REPORT. IN THIS PAGE I'D LIKE TO ADD SOME OF MY EXTERNAL STUFFS THAT WOULD DEFINITELY BE HELPFUL FOR FUTURE PURPOSE IF YOU BOTHER TO WORK ON THE SAME PROJECT. AS LONG AS I BELIEVE, THIS PROJECT REPORT COVERS ALMOST EVERYTHING THAT IT REQUIRES TO HOLD FOR A COMPLETE & AN UNABRIDGED REPORT SHOULD DO. IT CONTAINS DATA FROM DATA SHEETS, WEB LINKS & JOURNALS SO IT OBVIOUSLY IS AN ACCURATE STUFF TO HEED ON.

ACTUALLY, THE MAIN PURPOSE OF THIS 'PERSONAL NOTE' PAGE IS THAT IN PDF I CAN'T ADD ALL THE RELATED STUFF TO THE PROJECT. I MEAN THE VIDEO, IMAGES & PRESENTATION ETC. YOU KNOW, IT WOULD VERY UNHANDY & IT'D INCREASE THE SIZE OF DOCUMENT AT A GREAT EXTENT & IT DEFINITELY WOULD MAKE THE DOCUMENT VERY UNSTABLE. SO, TO DEAL WITH THIS PROBLEM I'VE FIND A WAY TO PROVIDE YOU A LINK TO AN ORGANIZED STACK THAT'D LEAD YOU TO THE RELATED STUFF OF THE PROJECT. SO, PLEASE DO CLICK ON THE FOLLOWING ICON OF DELICIOUS.COM & GET THE STACK INTO YOUR BROWSER.

ABHI 



*EXTRA STUFF

1.3.1 Supply voltage

Most microcontrollers operate with the standard logic voltage of +5 V. Some microcontrollers can operate at as low as +2.7 V and some will tolerate +6 V without any problems. You should check the manufacturers' data sheets about the allowed limits of the power supply voltage.

A voltage regulator circuit is usually used to obtain the required power supply voltage when the device is to be operated from a mains adaptor or batteries. For example, a 5 V regulator is required if the microcontroller is to be operated from a 5 V supply using a 9 V battery.

1.3.2 The clock

All microcontrollers require a clock (or an oscillator) to operate. The clock is usually provided by connecting external timing devices to the microcontroller. Most microcontrollers will generate clock signals when a crystal and two small capacitors are connected. Some will operate with resonators or external resistor–capacitor pair. Some microcontrollers have built-in timing circuits and they do not require any external timing components. If your application is not time-sensitive you should use external or internal (if available) resistor–capacitor timing components for simplicity and low cost.

An instruction is executed by fetching it from the memory and then decoding it. This usually takes several clock cycles and is known as the *instruction cycle*. In PIC microcontrollers an instruction cycle takes four-clock periods. Thus, the microcontroller is actually operated at a clock rate which is a quarter of the actual oscillator frequency.

1.3.3 Timers

Timers are important parts of any microcontroller. A timer is basically a counter which is driven either from an external clock pulse or from the internal oscillator of the microcontroller. A timer can be 8-bits or 16-bits wide. Data can be loaded into a timer under program control and the timer can be stopped or started by program control. Most timers can be configured to generate an interrupt when they reach a certain count (usually when they overflow). The interrupt can be used by the user program to carry out accurate-timing-related operations inside the microcontroller.

Some microcontrollers offer capture and compare facilities where a timer value can be read when an external event occurs, or the timer value can be compared to a preset value and an interrupt can be generated when this value is reached.

It is typical to have at least one timer in every microcontroller. Some microcontrollers may have two, three, or even more timers where some of the timers can be cascaded for longer counts.

1.3.4 Watchdog

Most microcontrollers have at least one watchdog facility. The watchdog is basically a timer which is refreshed by the user program and a reset occurs if the program fails to refresh the watchdog. The

watchdog timer is used to detect a system problem, such as the program being in an endless loop. A watchdog is a safety feature that prevents runaway software and stops the microcontroller from executing meaningless and unwanted code. Watchdog facilities are commonly used in real-time systems where it is required to regularly check the successful termination of one or more activities.

1.3.5 Reset input

A reset input is used to reset a microcontroller. Resetting puts the microcontroller into a known state such that the program execution starts from address 0 of the program memory. An external reset action is usually achieved by connecting a push-button switch to the reset input such that the microcontroller can be reset when the switch is pressed.

1.3.6 Interrupts

Interrupts are very important concepts in microcontrollers. An interrupt causes the microcontroller to respond to external and internal (e.g. a timer) events very quickly. When an interrupt occurs the microcontroller leaves its normal flow of program execution and jumps to a special part of the program, known as the *Interrupt Service Routine (ISR)*. The program code inside the ISR is executed and upon return from the ISR the program resumes its normal flow of execution.

The ISR starts from a fixed address of the program memory. This address is also known as the *interrupt vector address*. For example, in a PIC16F84 microcontroller the ISR starting address is 4 in the program memory. Some microcontrollers with multi-interrupt features have just one interrupt vector address, while some others have unique interrupt vector addresses, one for each interrupt source. Interrupts can be nested such that a new interrupt can suspend the execution of another interrupt. Another important feature of a microcontroller with multi-interrupt capability is that different interrupt sources can be given different levels of priority.

1.3.7 Brown-out detector

Brown-out detectors are also common in many microcontrollers and they reset a microcontroller if the supply voltage falls below a nominal value. Brown-out detectors are safety features and they can be employed to prevent unpredictable operation at low voltages, especially to protect the contents of EEPROM-type memories.

1.3.8 Analogue-to-digital converter

An analogue-to-digital converter (A/D) is used to convert an analogue signal such as voltage to a digital form so that it can be read by a microcontroller. Some microcontrollers have built-in A/D converters. It is also possible to connect an external A/D converter to any type of microcontroller. A/D converters are usually 8-bits, having 256 quantisation levels. Some microcontrollers have 10-bit A/D converters with 1024 quantisation levels. Most PIC microcontrollers with A/D features have multiplexed A/D converters where more than one analogue input channel is provided.

The A/D conversion process must be started by the user program and it may take several hundreds of microseconds for a conversion to complete. A/D converters usually generate interrupts when a conversion is complete so that the user program can read the converted data quickly.

A/D converters are very useful in control and monitoring applications since most sensors (e.g. temperature sensor, pressure sensor, force sensor, etc.) produce analogue output voltages.

1.3.9 *Serial I/O*

Serial communication (also called RS232 communication) enables a microcontroller to be connected to another microcontroller or to a PC using a serial cable. Some microcontrollers have built-in hardware called USART (Universal Synchronous–Asynchronous Receiver–Transmitter) to implement a serial communication interface. The baud rate and the data format can usually be selected by the user program. If any serial I/O hardware is not provided, it is easy to develop software to implement serial data communication using any I/O pin of a microcontroller. We shall see in Chapter 4 how to use the PicBasic and PicBasic Pro statements to send and receive serial data from any pin of a PIC microcontroller.

Some microcontrollers incorporate SPI (Serial Peripheral Interface) or I²C (Integrated Inter Connect) hardware bus interfaces. These enable a microcontroller to interface to other compatible devices easily.

1.3.10 *EEPROM data memory*

EEPROM type data memory is also very common in many microcontrollers. The advantage of an EEPROM memory is that the programmer can store non-volatile data in such a memory, and can also change this data whenever required. For example, in a temperature monitoring application the maximum and the minimum temperature readings can be stored in an EEPROM memory. Then, if the power supply is removed for whatever reason, the values of the latest readings will still be available in the EEPROM memory.

PicBasic and PicBasic Pro languages provide special instructions for reading and writing to the EEPROM memory of a microcontroller which has such memory built-in.

Some microcontrollers have no built-in EEPROM memory, some provide only 16 bytes of EEPROM memory, while some others may have as much as 256 bytes of EEPROM memories.

1.3.11 *LCD drivers*

LCD drivers enable a microcontroller to be connected to an external LCD display directly. These drivers are not common since most of the functions provided by them can be implemented in software.

1.3.12 Analogue comparator

Analogue comparators are used where it is required to compare two analogue voltages. Although these circuits are implemented in most high-end PIC microcontrollers they are not common in other microcontrollers.

1.3.13 Real-time clock

Real-time clock enables a microcontroller to have absolute date and time information continuously. Built-in real-time clocks are not common in most microcontrollers since they can easily be implemented by either using a dedicated real-time clock chip, or by writing a program.

1.3.14 Sleep mode

Some microcontrollers (e.g. PIC) offer built-in sleep modes where executing this instruction puts the microcontroller into a mode where the internal oscillator is stopped and the power consumption is reduced to an extremely low level. The main reason of using the sleep mode is to conserve the battery power when the microcontroller is not doing anything useful. The microcontroller usually wakes up from the sleep mode by external reset or by a watchdog time-out.

1.3.15 Power-on reset

Some microcontrollers (e.g. PIC) have built-in power-on reset circuits which keep the microcontroller in reset state until all the internal circuitry has been initialised. This feature is very useful as it starts the microcontroller from a known state on power-up. An external reset can also be provided where the microcontroller can be reset when an external button is pressed.

1.3.16 Low power operation

Low power operation is especially important in portable applications where the microcontroller-based equipment is operated from batteries. Some microcontrollers (e.g. PIC) can operate with less than 2 mA with 5 V supply, and around 15 μ A at 3 V supply. Some other microcontrollers, especially microprocessor-based systems where there could be several chips may consume several hundred milliamperes or even more.

1.3.17 Current sink/source capability

This is important if the microcontroller is to be connected to an external device which may draw large current for its operation. PIC microcontrollers can source and sink 25 mA of current from each output port pin. This current is usually sufficient to drive LEDs, small lamps, buzzers, small relays, etc. The current capability can be increased by connecting external transistor switching circuits or relays to the output port pins.

These are some features Of PIC Controllers that I found while creating this doc. Unfortunately I forgot to add it in my Report so I'm Putting it at the last. I Strongly believe it is very well explained & understandable. Thanxx, - Abhi Sharma :)